

Logo of Organization.....

**Name of Organization.....**

Address of Organization.....

## BIDDING DOCUMENT

For

**Supply, Delivery and Installation of 1 kWp Institutional Solar  
PV System (ISPS) at  
Name of Institution.....  
Address.....**

Contract Identification Number: ...../2081/82/.....

*Issued by:*

.....**Name**

.....Address

Tel: .....

Email: .....

Date of Issue: .....

# Table of Contents

<b><u>Section-I: Invitation for Priced Quotation .....</u></b>	<b><u>3</u></b>
<b><u>Section-II: Conditions of Contract .....</u></b>	<b><u>5</u></b>
<b><u>Section-III: Schedule of Requirements .....</u></b>	<b><u>10</u></b>
<b><u>Section-IV: Technical Specifications.....</u></b>	<b><u>11</u></b>
<b><u>Section-V: Sample Forms .....</u></b>	<b><u>101</u></b>

## **Section-I: Invitation for Priced Quotation**

Dear Suppliers/Firms

1. The .....(*Purchaser*) invites Priced Quotations for the **Supply, Delivery and Installation of Institutional Solar PV System (ISPS)** as detailed in attached Specifications and the Schedule of Requirements provided herein.
2. The Price Quotation submitted by the Bidder shall comprise the following:
  - a. Quotation and Price Schedules
  - b. Declaration of Undertaking
  - c. Schedule of Requirements
  - d. Technical Specifications (including the Technical Form - Annex A of Section IV)
3. A prospective Supplier/Bidder may obtain clarification on the Priced Quotation Form from the Purchaser on or before 2 days prior to the deadline for submission of Priced Quotation.
4. Sealed Price Quotation in the sealed Single Envelope must be submitted to the office of.....(*Purchaser*) on or before .....**Time** on .....**Date (Providing minimum 7 days for quotation submission)**.
5. The Bidder shall indicate on the Price Schedule the unit prices (where applicable) and total price of the goods to be supplied under the contract. All duties, taxes and other levies payable by the Supplier/Bidder under the contract shall be included in the rates, prices and total Bid Price submitted by the Bidder. From the total Bid Price, the Bidder shall show all duties, taxes, import duties and other levies applicable for the contract separately and clearly.
6. Price quoted by the Bidder shall remain fixed and valid until completion of the Contract Performance and will not be subject to variation in any account.
7. Submitted Priced Quotations must remain valid for a period of **30 days** from the date of submission of Priced Quotations.
8. The Bidder shall furnish, as part of its bid, documents establishing the Supplier's/ Bidder's eligibility to bid and qualification to perform the contract if the bid is accepted. Documents to establish such eligibility shall be but not limited to the following:
  - a) A Copy of Up to date Firm/Company Registration Certificate
  - b) A Copy of VAT/PAN Registration Certificates
  - c) A Copy of Tax Clearance Certificate of F. Y. 2080/81 B.S.
  - d) Power of Attorney (if other than owner's Signature on document)
  - e) Manufacturer's Authorization Certificate
  - f) Declaration of Undertaking
9. The goods supplied under this contract shall conform to the Schedule of Requirements (Section III) and the standards mentioned in the Technical Specification (Section IV).
10. If the last date of submission and opening falls on a government holiday, then the next working day shall be considered the last day.
11. Bid Evaluation will be done in following order and only successful bidders from earlier stage evaluation shall be recommended for next stage evaluation:
  - a) Examination of completeness of bidder's quotation;
  - b) Eligibility examination;
  - c) Technical Evaluation; and
  - d) Financial Evaluation

12. Technical evaluation and other eligibility criteria will be based on PASS/FAIL Criteria. For the quotation fulfilling all eligibility and technical requirements, the financial evaluation will be performed. Substantially responsive lowest evaluated quotation will be awarded.
13. The Purchaser reserves the right to accept or reject the Price Quotations according to provisions defined in existing PPA/PPR.

Yours sincerely,

**Signature:**.....  
**Name**.....  
**Position**.....  
**Organization**.....(*Purchaser*)  
**Address**.....

## **Section-II: Conditions of Contract**

<b>1. Definitions</b>	<p>1.1 In this contract, the following terms shall be interpreted as indicated:</p> <ol style="list-style-type: none"> <li>a. "The Contract" means the agreement entered into between the Purchaser and the Supplier, as recorded in the Contract Form Signed by the parties, including all attachments and appendices thereto and all documents incorporated by reference therein;</li> <li>b. "The Contract Price" means the price payable to the Supplier under the contract for the full and proper performance of its contractual obligation;</li> <li>c. "The Goods" means Equipment and related Accessories and spare-parts or any other materials which the Supplier is required to supply to the Purchaser under the contract;</li> <li>d. "Services" means services ancillary to the supply of the goods such as transportation and insurance including the installation, commissioning and the operational and maintenance training of the supplied equipment, as per requirement defined in Section IV.</li> <li>e. "The Purchaser" means the procuring entity purchasing the goods;</li> <li>f. "The Supplier" means the organization supplying the goods and services under this contract. The Supplier is also referred as "Installation Company"</li> <li>g. The "Source of Fund" for this Project is from KfW and Government of Nepal.</li> </ol>
<b>2. Technical Specification</b>	<p>2.1 The goods supplied under this contract shall confirm to the requirements and standards mentioned in the Technical Specification (Section IV).</p>
<b>3. Patent Right</b>	<p>3.1 The Supplier shall indemnify the Purchaser against all third-party claims of infringement of patent, trademark or industrial design rights arising from use of goods or any part thereof in the Purchaser's country.</p>
<b>4. Inspection and Tests</b>	<p>4.1 The Purchaser or AEPC or their Representative shall inspect and/or test the goods to confirm their conformity to the Technical Specification and the quality of performance after the submission of subsidy application form by the Supplier on behalf of the Purchaser.</p> <p>4.2 Inspection, Testing and Commissioning will be performed to verify the information provided in Subsidy Application Form, to verify all technical requirements presented in Section IV.</p> <p>4.3 If upon the Inspection and Test, the actual installation do not comply with the requirements from Section IV, then testing and commissioning shall not be considered in Successful. In which case, the Supplier shall correct the identified defects/noncompliance within 15 days and provide the proof of correction and request for re-inspection/commissioning.</p> <p>4.4 If upon the re-inspection/commissioning, the project does-not comply with the Testing and commissioning requirements mentioned in Section</p>

	<p>IV, then the system will be rejected and the supplier shall be responsible for all cost and removal of material/equipment from the site.</p> <p>4.5 In case re-inspection/commissioning is required due to the fault of the Supplier, the additional cost for brining the independent expert on behalf of AEPC during re-inspection/commissioning shall be borne by the Supplier.</p>
<b>5. Packing</b>	<p>5.1 The Supplier shall provide such packing of the goods as is required to prevent their damage or deterioration during transmit to their final destination as indicated in the contract.</p> <p>5.2 The packing shall be sufficient to withstand, without limitation, rough handling during transit and exposure to extreme temperatures, salt and precipitation during transit and open storage.</p> <p>5.3 The packing, marking and documentation within and outside the packages shall comply strictly with such special requirements as shall be expressly provided in accordance with international standard and practice.</p>
<b>6. Delivery of Goods and Related Services, and Delay Liquidated Damage</b>	<p>6.1 Delivery of the goods and Related Service shall be made by the Supplier in accordance with the terms specified by the Purchaser in its Schedule of Requirements.</p> <p>6.2 Delivery of the goods and Related Service meaning the complete delivery of all equipment's and complete installation of all equipment and accessories and the system shall be ready for inspection, test and commissioning.</p> <p>6.3 Once the Supplier completes the delivery and installation of all equipment and accessories, the Supplier on behalf of the Purchaser submits the Subsidy Application Form and supportive documents (one electronic and one hard copy), to Alternative Energy Promotion Centre (AEPC).</p> <p>6.4 Upon the submission of Subsidy Application and within 30 days of such submission Inspection, Testing and Commissioning shall be performed, under agreement between AEPC, Supplier and the Purchaser, as shown in clause 4.</p> <p>6.5 If the Supplier fails to deliver any or all of the Goods or perform the Related Services within the Completion Time specified in the Contract, the Purchaser may without prejudice to all its other remedies under the Contract, deduct from the Contract Price, as liquidated damages (called Delay Liquidated Damage), a sum equivalent to 0.05% the Contract Price for each day of delay, up to a maximum deduction of 10% of the Contract Price. Once this maximum is reached, the Purchaser may terminate the Contract.</p>
<b>7. Warranty</b>	<p>7.1 The Supplier warrants that all the goods supplied under the contract shall fully comply with the specification laid down in the contract.</p>

	<p>7.2 The warranty shall remain valid for two years after the goods have been delivered to the final destination indicated in the contract and accepted by the Purchaser after installation and commissioning of equipment by the Supplier.</p> <p>7.3 The Purchaser shall promptly notify the Supplier in writing of any claims arising under this warranty.</p> <p>7.4 Upon receipt of such notice, the Supplier shall, with all reasonable speed, replace the defective goods without cost to the Purchaser. The Supplier will be entitled to remove, at its own risk and cost, the defective goods.</p>
<b>8. Payment</b>	<p>8.1 Payment of the goods supplied shall be made in Nepali Rupees after the delivery and installation, and commissioning of goods according to requirements set in section IV of this document.</p> <p>8.2 Payment shall be made within fifteen (15) days after entire task completion and upon submission of claim supported by the Testing and Commissioning Report issued by the Purchaser.</p> <p>8.3 Advance and installment will not be paid.</p> <p>8.4 All invoices shall show clearly and separately the all duties, taxes, import duties and other levies related to such payments.</p>
<b>9. Prices</b>	<p>9.1 Prices charged by the Supplier for goods delivered under the contract shall not vary from the prices quoted by the Supplier in its price quotation.</p>
<b>10. Insurance</b>	<p>10.1 The Supplier will be responsible for taking out any insurance coverage against loss or damage incidental to manufacture or acquisition, transportation, storage, delivery and installation until the completion of ISPS installation and handover to the beneficiary institution.</p>
<b>11. Governing Language</b>	<p>11.1 The Governing Language shall be: Nepali or/and English. Documents in English shall prevail in case of ambiguity or conflict other than National Laws and Regulations.</p>
<b>12. Applicable Law</b>	<p>12.1 The applicable law shall be Laws of Nepal.</p>
<b>13. Notices</b>	<p>13.1 Purchaser's address for notice purposes: .....</p> <p>13.2 Supplier's address for notice purposes: .....</p>
<b>14. Taxes and Duties</b>	<p>14.1 The Supplier shall be entirely responsible for all taxes, duties, licence fees and other such levies imposed by the GoN.</p>
<b>15. Operation, Maintenance and Spare-parts Manuals</b>	<p>15.1 The successful Supplier shall supply 2 copies of manufacturer's operation, maintenance and spare-part manuals of the goods (Equipment).</p> <p>15.2 The successful Supplier shall provide the After sales service according to requirement set in Section IV.</p>

<p><b>16. Conduct of Suppliers</b></p>	<p>16.1 The Supplier shall be responsible to fulfil his obligations as per the requirement of the Contract Agreement, Bidding documents, GoN's Procurement Act and Regulations.</p> <p>16.2 The Supplier shall not carry out or cause to carry out the following acts with an intention to influence the implementation of the procurement process or the procurement agreement :</p> <ol style="list-style-type: none"> <li>a. give or propose improper inducement directly or indirectly,</li> <li>b. distortion or misrepresentation of facts</li> <li>c. engaging or being involved in corrupt or fraudulent practice</li> <li>d. interference in participation of other prospective bidders.</li> <li>e. coercion or threatening directly or indirectly to impair or harm, any party or the property of the party involved in the procurement proceedings,</li> <li>f. collusive practice among bidders before or after submission of bids for distribution of works among bidders or fixing artificial/uncompetitive bid price with an intention to deprive the Purchaser the benefit of open competitive bid price.</li> <li>g. contacting the Purchaser with an intention to influence the Purchaser with regards to the bid or interference of any kind in examination and evaluation of the bids during the period after opening of bids up to the notification of award of contract</li> </ol>
<p><b>17. Blacklisting Supplier</b></p>	<p>17.1 The GoN, Public Procurement and Monitoring Office(PPMO) may blacklist a Supplier for his conduct up to three years on the following grounds and seriousness of the act committed by the supplier:</p> <ol style="list-style-type: none"> <li>a. if it is proved that the supplier committed acts pursuant to the Sub - clause 16.2,</li> <li>b. if it is proved later that the supplier had committed substantial defect in implementation of the contract or had not substantially fulfilled his obligations under the contract or the completed work is not of the specified quality as per the contract ,</li> <li>c. if convicted by a court of law in a criminal offence which disqualifies the supplier from participating in the contract.</li> <li>d. if successful Supplier fails to sign the Contract.</li> </ol> <p>17.2 A Supplier declared blacklisted and ineligible by the GoN shall be ineligible to bid for a contract during the period of time determined by PPMO.</p>
<p><b>18. Dispute Resolution</b></p>	<p>18.1 Any dispute arising out of the Contract, which cannot be amicably settled between the parties, shall be referred to adjudication.</p>
<p><b>19. Retention</b></p>	<p>19.1 Ten percent (10%) of subsidy amount will be deducted at the time of final payment. The deducted subsidy amount will be released/refunded after completion of Warranty/Guarantee period and motoring by AEPC.</p> <p>19.2 All reimbursements, insurance payments, guarantee payments or similar payments, if any, shall be made for the account of the Purchaser to KfW, Frankfurt am Main, BIC: KFWIDEFF, IBAN: DE53 5002 0400 3800 0000 00, which KfW shall credit to the Purchaser. If such payments are made in local currency (NPR), they shall be remitted to special account as mentioned below and will be drawn on only with consent to KfW. Account No: 00131400374035000048</p>

	Bank Name: NMB Bank Ltd. Address: Babarmahal, Kathmandu, Nepal
<b>20. Provision of PPA and PPR</b>	<p>20.1 If any provision of this document is inconsistent Public Procurement Act (PPA), 2063 or Public Procurement Regulations (PPR), 2064, the provision of this documents shall be void to the extent of such inconsistency and the provision of PPA and PPR shall prevail.</p> <p>20.2 In case a situation arises the provision of such inconsistency is neither covered by the tender documents nor by the referenced PPA/PPR in 20.1, then KfW Procurement guidelines January 2019 version shall prevail, and the provision of this documents shall be void to the extent of such inconsistency.</p>

## **Section-III: Schedule of Requirements**

<b>S.N.</b>	<b>Description</b>	<b>Quantity</b>	<b>Place of Delivery</b>	<b>Delivery Schedule</b>
1	Supply, Delivery, Installation, Commissioning and After Sales Service of <b>1 kWp</b> Institutional Solar PV System (ISPS)	1 (One Set)	.....	Within 45 days from The Date of Agreement/Purchase Order

The contract will be effective from the date of signing of agreement or the date mentioned in the agreement. Entire task needs to be completed by the selected bidder/supplier within 45 (Forty-five) days from the effective date of agreement at the site.

## **Section-IV: Technical Specifications**

<b>1</b>	<b>SCOPE OF WORK.....</b>	<b>16</b>
1.1	Design Requirements .....	17
1.2	PIT and RST Certificates .....	17
<b>2</b>	<b>SPECIFIC TECHNICAL SPECIFICATIONS .....</b>	<b>18</b>
2.1	PV Modules .....	18
2.2	Battery .....	19
2.3	Solar Charge Controller (SCC).....	19
2.4	Inverter .....	20
2.5	Lightning Protection System and Earthing.....	21
2.5.1	Practical Technical Note on Lightning Protection Installation .....	21
2.5.2	Technical Requirements .....	27
2.5.3	Earthing .....	31
2.6	Installation.....	33
2.6.1	General.....	33
2.6.2	PV Array .....	34
2.6.3	Battery bank .....	36
2.6.4	Cables .....	36
2.6.5	Building internal electrical installation .....	38
<b>3</b>	<b>TESTING AND COMMISSIONING.....</b>	<b>38</b>
<b>4</b>	<b>MINIMUM SPARE PARTS AND TOOLS .....</b>	<b>39</b>
<b>5</b>	<b>DOCUMENTATION.....</b>	<b>39</b>
5.1	On-site Documentation.....	39
5.2	Project Completion Report.....	40
<b>6</b>	<b>TRAINING .....</b>	<b>40</b>
<b>7</b>	<b>WARRANTY.....</b>	<b>41</b>
<b>8</b>	<b>AFTER SALES SERVICE .....</b>	<b>41</b>
<b>9</b>	<b>ENVIRONMENTAL AND SOCIAL MANAGEMENT PLAN (ESMP).....</b>	<b>42</b>

**10 ANNEXES ..... 43**

**10.1 Annex A: Bidder’s Technical Form (to be completed by the Bidder)..... 43**

**10.2 Annex B: Electrical Design Requirements for public buildings (NBC 207:2003)  
47**

**10.3 Annex C: Testing and Commissioning Form..... 66**

**10.4 Annex D: Environmental and Social Management Plan (ESMP) ..... 93**

## LIST OF FIGURES

Figure 1-1: ISPS typical Single Line Diagram (indicative only).....	16
Figure 2-1: PV array layout and definition (valid for ground-mounted or rooftop installations) ..	22
Figure 2-2: Maximum size of the PV array (profile view) for the proposed LPS design .....	22
Figure 2-3: Separation distances (S) for ground-mounted installations .....	23
Figure 2-4: Separation distance (S) for roof-mounted installations .....	24
Figure 2-5: LPS design for PV array length comprised between 4m and 14m (roof-mounted installations).....	25
Figure 2-6: LPS design for PV array length comprised between 4m and 14m (ground-mounted installation) .....	25
Figure 2-7: LPS design for PV array length lower or equal to 4m .....	26
Figure 2-8: SPD requirements (location and type) .....	29
Figure 2-9: Earthing requirements .....	32
Figure 2-10: Warning stickers to be installed close to the battery bank in the technical room ...	33

## LIST OF TABLES

Table 1-1: Summary of the minimum capacity for the key components .....	16
Table 1-2: Summary of the minimum key requirements .....	17
Table 2-1: Minimum separation distance ( $S_{min}$ ) for roof-mounted installations.....	23
Table 2-2: SPD characteristics.....	30
Table 2-3: Maximum values of cabling losses (1 kWp system) .....	37
Table 4-1: Spare parts and tools – to be provided by the Installation Company .....	39
Table 7-1: Product warranty for the major components.....	41

## LIST OF ABBREVIATIONS

AEPC	Alternative Energy Promotion Centre
BoS	Balance of System
ESMP	Environmental and Social Management Plan
HVD	High Voltage Disconnection
IEC	International Electrotechnical Commission
IP	Ingress Protection
ISO	International Organization for Standardization
kW	kilo Watt
kWp	kilo Watt peak (unit used for defining electrical power of photovoltaic modules)
LPS	Lightning Protection System
LVD	Low Voltage Disconnection
LVR	Low Voltage Reconnection
MPPT	Maximum Power Point Tracking
MCB	Miniature Circuit Breaker
NEPQA	Nepal Photovoltaic Quality Assurance
O&M	Operation and Maintenance
PIT	Product Introduction Test
PV	Photovoltaic
PWM	Pulse Width Modulation
RETS	Renewable Energy Test Station
RST	Random Sampling Test
SAF	Subsidy Application Form
SCC	Solar Charge Controller
SPD	Surge Protection Device
STC	Standard Test Condition (Irradiation 1000W/m <sup>2</sup> , Air Mass 1.5 and Cell Temperature 25°C)
VRLA	Valve Regulated Lead Acid
Wp	Watt peak (unit used for defining electrical power of photovoltaic modules)

# 1 SCOPE OF WORK

The scope of work of the Supplier (also called Installation Company “IC”) shall include all necessary components for the turn-key installation of an Institutional Solar Photovoltaic System (ISPS), including supply of equipment, delivery on site, installation of the PV system and electrical circuits, testing and commissioning, training to the Institution representatives and after sale service for a period of two years.

Annex A includes the form to be completed at the bidding stage, as well as the documentation to be provided with the quotation.

**Table 1-1: Summary of the minimum capacity for the key components**

1 kWp system		
Item	Component	Minimum Capacity
1	Solar PV Array	Total Peak Power: 1,000 Wp
2	Solar Charge Controller (SCC)	DC Input: 1,400 Wp
3	Battery Bank	Capacity: 7,200 Wh (C10)
4	Inverter	Nominal Power: 2,000 VA

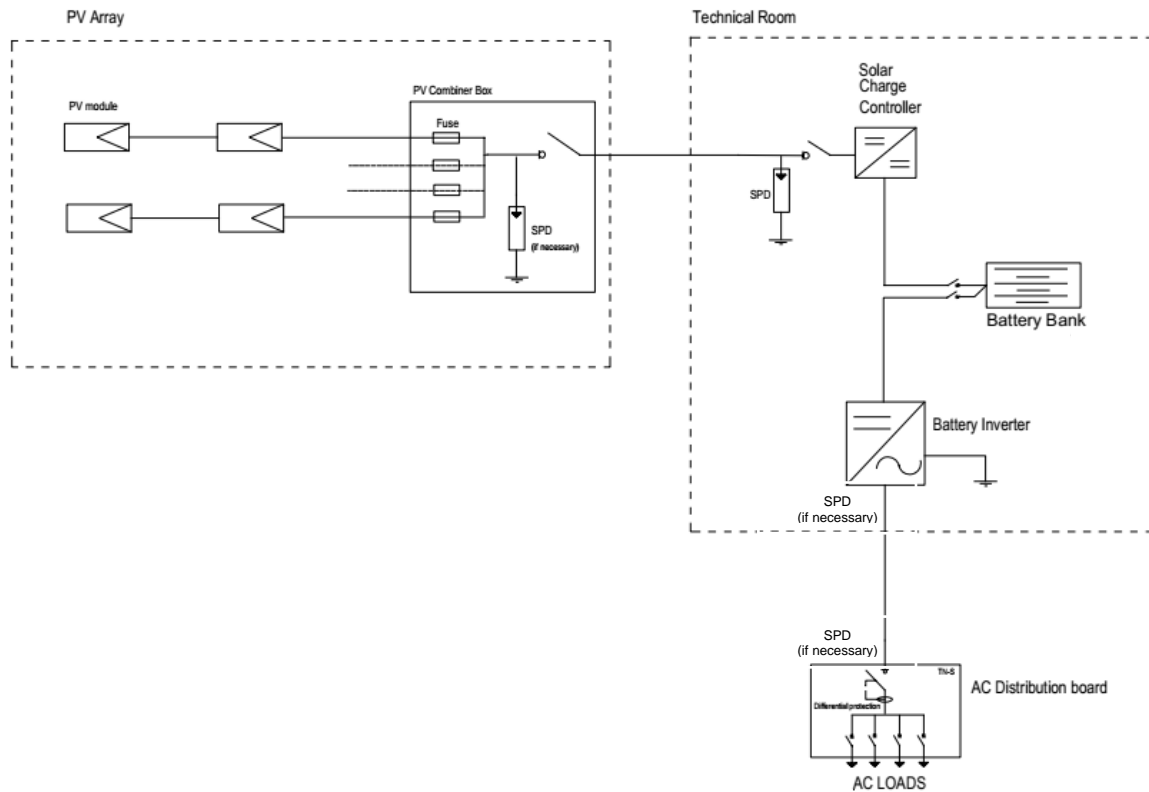

**Figure 1-1: ISPS typical Single Line Diagram (indicative only)**

## 1.1 Design Requirements

**Table 1-2: Summary of the minimum key requirements**

1 kWp system		
Item	Component	Minimum Key Requirements
1	Solar PV Array	Total Peak Power: 1,000 Wp PV module $\geq$ 100 Wp Crystalline Silicon (c-Si) technology See section 2.1
2	Solar Charge Controller (SCC)	DC Input: 1,400 Wp MPPT or PWM Type. See section 2.3
3	Battery Bank	Capacity: 7,200 Wh (C10) Tubular Lead Acid Flooded or sealed (VRLA) Parallel string connection $\leq$ 4 See section 2.2
4	Inverter	Nominal Power: 2,000 VA See section 2.4
5	Mounting structure	Orientation: South Inclination: 30° Structure Material: Aluminium or Hot Dip Galvanized Steel (with a minimum coating thickness of 70 $\mu$ m) Accessories: Aluminium/Stainless steel (SAE 304) Design lifetime: 20 years Withstand 180 km/hr maximum wind speed
6	Installation	As per requirements in section 2.6
7	Lightning Protection System and Earthing	As per requirements in section 2.5
8	Cables and conduits	As per requirements in section 2.6.4 Maximum cabling losses as per Table 2-3
9	System Voltage	24/48V to be selected by the Installation Company as per proposed components and design Compatibility with all system components shall be ensured

## 1.2 PIT and RST Certificates

PIT (Product Introduction Test) and RST (Random Sampling Test) certificates are applicable for PV Modules, Solar Charge Controller, Battery and Inverter. PIT Certificates must be submitted with the quotation at the bidding stage.

RST Certificates can be provided at the bidding stage if available but must be submitted at the latest within the deadline of completion of project (before the testing and commissioning takes place). If a product fails to comply with the NEPQA (Nepal Photovoltaic Quality Assurance) requirements, AEPC will not provide subsidy for such system.

## 2 SPECIFIC TECHNICAL SPECIFICATIONS

Compliance with the requirements of the latest edition of NEPQA is verified by PIT and RST certificates. This section details additional specific requirements to NEPQA which shall be considered by the Installation Company for the component selection, design and installation of the system.

### 2.1 PV Modules

Additionally to the latest NEPQA requirements, the following specific requirements are applicable:

- PV module technology shall be crystalline silicon (c-Si - mono or poly);
- PV modules shall be certified (by an independent accredited laboratory) compliant with:
  - IEC 61215 (Terrestrial photovoltaic PV modules - Design qualification and type approval)
  - IEC 61730 (PV module safety qualification)
  - For both international standards above, test reports and certificates issued by an independent accredited laboratory shall be provided with the quotation (validity date of the certificate shall be at least 6 months after the date of the quotation)
- PV module warranty against design and manufacturing defects shall be minimum 5 years for modules up to 150 Wp and 10 years for modules greater than 150 Wp;
- The PV module original manufacturer shall have:
  - Minimum 5 years of PV Module manufacturing experience. Evidence of manufacturing experience shall be provided with the quotation
  - ISO 9001 and ISO 14001 certification. Evidences shall be provided with the quotation
- For PV modules above 250 Wp, the minimum efficiency shall be 15%;
- PV module tolerance on the nominal peak power (nameplate at STC) shall be positive and no more than 5%;
- Junction box (located on the back side of the module) shall be rated at least IP65 according to IEC 60529;
- All PV modules to be installed shall be of same type, same model and same power rating (from same manufacturer) for each individual site;
- PV module capacity shall be more than 100 Wp;
- PV modules must be warranted for their rated output, with a minimum of 90% at year 10 and a minimum of 80% at year 25.

## 2.2 Battery

Additionally to the latest NEPQA requirements, the following specific requirements are applicable:

- The battery original manufacturer shall have:
  - Minimum 3 years of battery manufacturing experience. Evidence of manufacturing experience shall be provided with the quotation
  - ISO 9001 and ISO 14001 certification. Evidences shall be provided with the quotation
- Original battery documentation shall clearly indicate:
  - the recommended voltage values for battery protection (Low Voltage, Reconnection Voltage, and High Voltage) and normal charging to facilitate the solar charge controller programming
  - the curve showing the quantity of cycles versus the depth of discharge (confirming at least 1,500 cycles at 70% depth of discharge as per NEPQA requirement)
- All batteries to be installed shall be of same type, same model and same capacity rating (from same manufacturer) for each individual site;
- Self discharge shall be  $\leq 3\%$  per month at 25°C.

## 2.3 Solar Charge Controller (SCC)

Additionally to the latest NEPQA requirements, the following specific requirements are applicable:

- SCC shall be compliant with applicable requirements stated in:
  - IEC 62109 (Safety of power converters for use in photovoltaic power systems)
  - IEC 62509 (Battery charge controllers for photovoltaic systems - Performance and functioning)
  - A certificate issued by a third-party accredited laboratory or a statement provided by the principal SCC manufacturer (signed document with letter head) shall be provided with the quotation
- The SCC manufacturer shall have:
  - Minimum 3 years of SCC manufacturing experience. Evidence of manufacturing experience shall be provided with the quotation
  - ISO 9001 and ISO 14001 certification. Evidences shall be provided with the quotation
- SCC shall be installed indoor and shall be rated at least IP21 according to IEC 60529;
- SCC shall have a display indicating the battery voltage/the state of charge, charging and discharging currents, current functioning status, and alarms;

- SCC shall include reverse polarity protection (on PV module and battery sides), overtemperature protection and reverse current protection at night;
- The voltage range for Low Voltage Disconnection (LVD), Low Voltage Reconnection (LVR) and High Voltage Disconnection (HVD) functions within the SCC shall be compatible with the recommendations of the battery manufacturer. The confirmation of these values shall be provided by both manufacturers and compatibility will be verified during testing and commissioning.

In-built solar charge controllers in the inverter are accepted as long as they meet the technical requirements as mentioned above. In case of in-built SCC within the inverter, only the PIT and RST certificate of the inverter is required.

## 2.4 Inverter

Additionally to the latest NEPQA requirements, the following specific requirements are applicable:

- The inverter shall deliver a pure sine wave voltage (AC output voltage of 230 V, 50 Hz);
- The inverter shall be compliant with applicable requirements stated in:
  - IEC 61000-6-1 (Electromagnetic compatibility - Immunity standard) and IEC 61000-6-3 (Electromagnetic compatibility - Emission standard)
  - IEC 62109 (Safety of power converters for use in photovoltaic power systems)
  - For both international standards above, a certificate issued by a third-party accredited laboratory or a statement provided by the principal inverter manufacturer (signed document with letter head) shall be provided with the quotation
- Product warranty from the manufacturer shall be 3 years;
- The inverter shall indicate its functioning status (output power, battery state and alarm), at least with LED signals;
- The inverter shall include:
  - A stand-by function for which self-consumption during stand-by (i.e. no load but in load detection mode) shall not be more than 1% of the rated power
  - An automatic load detection function which allows the inverter to be in a stand-by mode when there is no electrical demand. This option enables to limit the battery discharge due to self-consumption of the inverter (especially at night)
- The inverter manufacturer shall have:
  - Minimum 3 years of inverter manufacturing experience. Evidence of manufacturing experience shall be provided with the quotation
  - ISO 9001 and ISO 14001 certification. Evidences shall be provided with the quotation
- The inverter shall be installed indoor and shall be rated at least IP21 according to IEC 60529;

- The inverter shall be able to operate with a power factor range from 0.5 to 1;
- Compatibility between inverter LVD, LVR and HVR range/values and battery manufacturer recommendations and solar charge controller disconnection voltage shall be verified according to the design (direct connection of the inverter to the battery or not).

## 2.5 Lightning Protection System and Earthing

The Lightning Protection System (LPS) shall be of the enhanced type which is designed to attract lightning to a preferred point and safely convey the lightning energy to ground with minimal risk of side flashing via a pre-determined route. The complete LPS will comprise the following key components:

- a) Air-termination system: composed of the air-terminal rod intended to intercept lightning flashes
  - b) Down conductor system: intended to conduct lightning current from the air-termination system to the earth-termination system
  - c) Earth-termination system: intended to conduct and disperse lightning current into the earth with the use of earthing electrodes
  - d) Surge Protection Devices (SPD): intended to limit transient overvoltage and divert surge current
- a), b) and c) together are also referred as the external LPS.

### 2.5.1 Practical Technical Note on Lightning Protection Installation

In the present section, some practical design parameters and requirements are presented to support the correct design and installation of the LPS in the specific environment of ISPS.

#### 2.5.1.1 Design parameters

The proposed LPS design is valid under the following assumptions:

- For PV ground-mounted installation, the external LPS (especially the air-terminal rod) **is always isolated** from any metallic parts of the PV array (minimum separation distance shall be maintained). The Minimum Separation Distance is defined in section 2.5.1.2.
- For PV roof-mounted installation, the external LPS (especially the air-terminal rod) can **be isolated** (minimum separation distance maintained) **or not isolated** (minimum separation distance not maintained) from any metallic parts of the PV array, depending on the available space on the roof.
- It is expected that the PV array (roof-mounted or ground-mounted) will be composed of one or several adjacent rows depending on the PV array size and site constraints, as shown on the following picture. Each row can be divided into several separate sub-arrays.

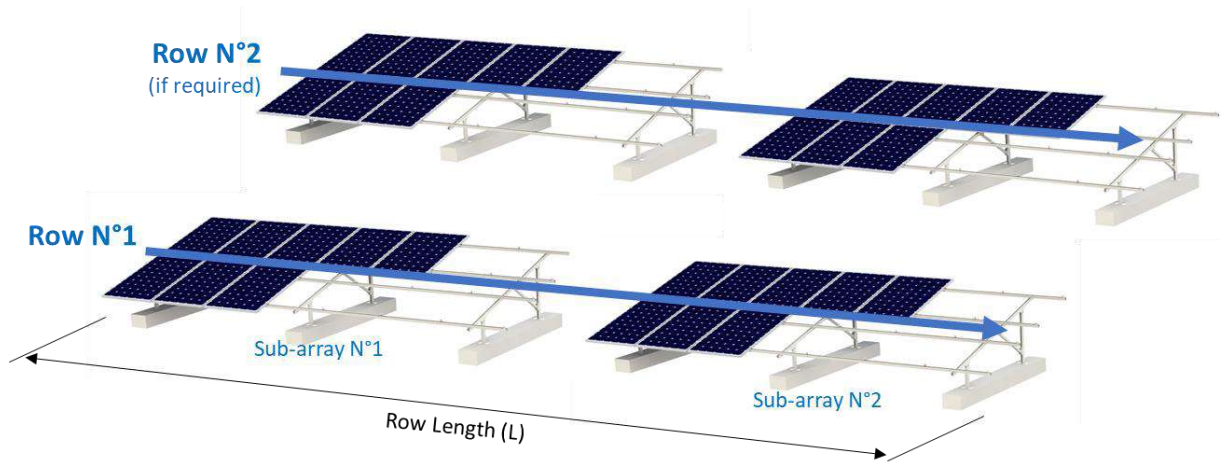

**Figure 2-1: PV array layout and definition (valid for ground-mounted or rooftop installations)**

The width of the PV array is assumed to be maximum 5 meters. The lower front part of the PV array is assumed to be not higher than 2 meters from ground level (for ground-mounted installations) and not higher than 0.5 meters from roof level for roof-top installations. The inclination of the PV array is assumed to be maximum 35°, as illustrated on the following figure:

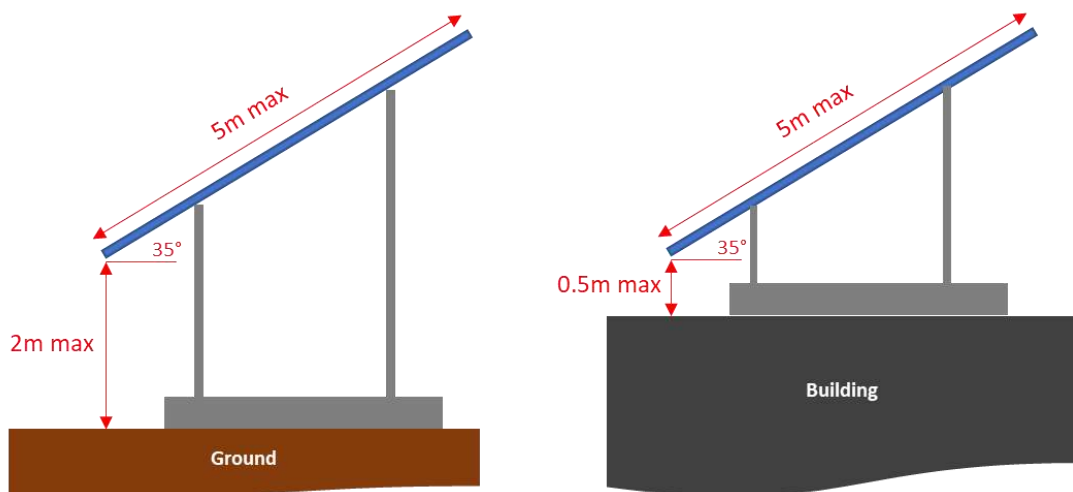

**Figure 2-2: Maximum size of the PV array (profile view) for the proposed LPS design**

The lightning protection area is determined by the rolling sphere method.

The diameter of the rolling sphere is depending on the class of LPS. Due to the absence of reliable data regarding keraunic level in the different regions of Nepal, it is recommended to consider a Class I for the LPS of ISPS. This represents the maximum protection level (conservative approach) which is justified by the medium to high density of lightning expected in the project area (especially in regions of altitude), the remoteness of the site and the corresponding difficulty to replace equipment in case of damage. For LPS Class I, a radius of rolling sphere of 20 m is considered, as per IEC 62305-3.

### 2.5.1.2 Minimum separation distance ( $S_{min}$ )

The separation distance ( $S$ ) is the distance between the air-terminal rod (and the external LPS in general) and the closest metallic part of the PV array, as illustrated on the graphs below. Based on

the design parameters presented above, the following installation requirements and LPS design shall be followed:

- For PV ground-mounted installations, the separation distance (S) shall be more than **0.40 meter (S<sub>min</sub>)** when the air-terminal rod is installed on its own concrete base (or foundation) with support accessories or more than **0.60 meter (S<sub>min</sub>)** when the air-terminal rod is fixed on the PV mounting structure with glass-fibre reinforced UV resistant plastic holders (material factor km > 0.7);

Metallic fences shall be preferably placed at a distance from the air-termination system of at least 1 meter, but in all cases not less than 0.6 meter.

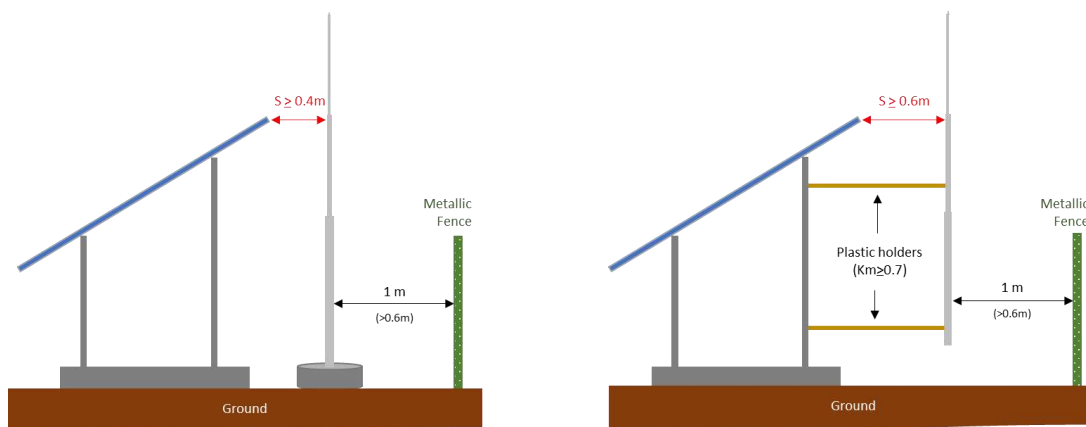

**Figure 2-3: Separation distances (S) for ground-mounted installations**

- For roof-mounted installations, the minimum separation distance shall be according to the below table:

**Table 2-1: Minimum separation distance (S<sub>min</sub>) for roof-mounted installations**

Length of the down conductor [m]	Minimum separation distance (S <sub>min</sub> ) [m]	
	Air-terminal rods installed on its own concrete base	Air-terminal rods fixed on PV mounting structure with glass-fibre holders (km>0.7)
3	0.64	0.92
5	0.80	1.15
7	0.96	1.38
9	1.12	1.60
11	1.28	1.83
12	1.36	1.95
15	1.60	N/A*
17	1.76	N/A*
20	N/A*	N/A*
25	N/A*	N/A*
30	N/A*	N/A*

N/A\*: in this case, the mounting structure must be connected to the air-terminal system (external LPS) with copper conductor having a cross-section of at least 16 mm<sup>2</sup> AND with an actual separation distance inferior to 1 meter

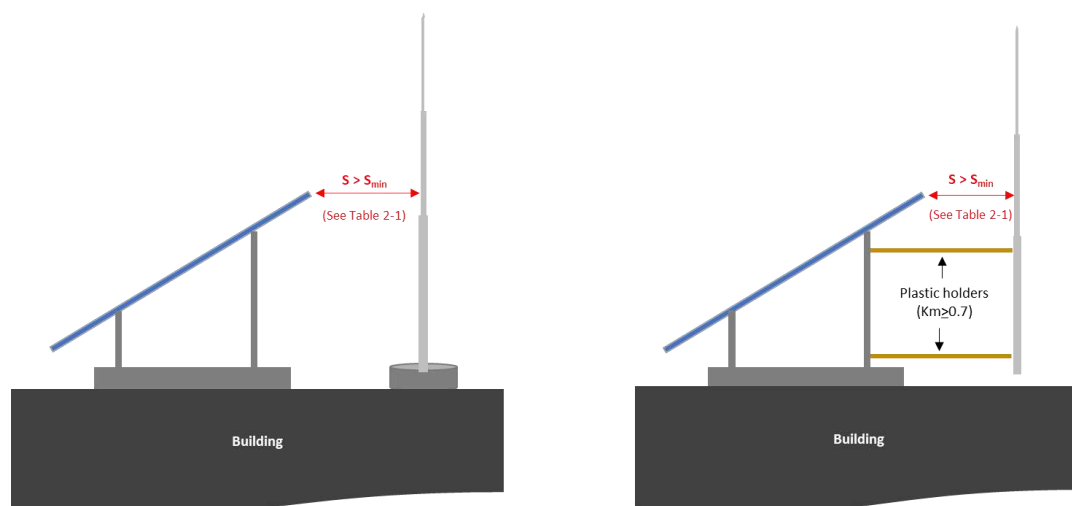

**Figure 2-4: Separation distance (S) for roof-mounted installations**

For roof-mounted installations, there are two special cases which require the direct connection between the PV mounting structure and the air-termination system with copper conductor having a cross-section of at least 16 mm<sup>2</sup> or equivalent in order to be able to carry lightning currents, as follows:

- In case the roofing is made of metal or if the minimum separation distance cannot be maintained due to space limitation on the roof area or difficult installation conditions of air-terminal rods (i.e. inclined roofs)
- For high buildings, where the minimum separation distance is marked N/A in Table 2-1 (yellow coloured cells,  $S_{min} > 2$  meters), the air-terminal rods shall be mounted without considering the minimum separation distance and the actual separation distance (S) shall be not higher than 1 meter

### 2.5.1.3 Quantity and Height of the air-terminal rod(s)

There are two cases to consider, depending on the total length L of the PV row (as per Figure 2-1).

- **Case 1:** L is more than 4 meters and less than 14 meters ( $4m < L \leq 14m$ )
  - **Two air-terminal rods** shall be installed as minimum for each row of the PV array. The air-terminal rods shall have a total height sufficient to have the top part standing:
    - For roof-top installations:
      - **one (1) meter** above any part of the PV array if the separation distance (S) is **inferior or equal** to 1 meter
      - **two (2) meters** above any part of the PV array if the separation distance (S) is **superior** to 1 meter

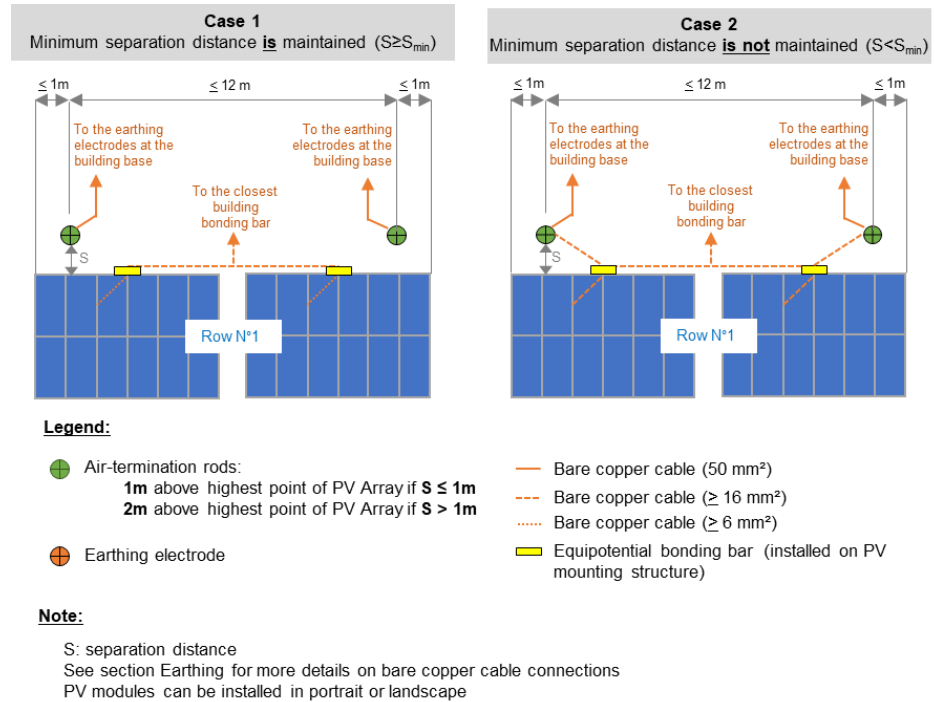

**Figure 2-5: LPS design for PV array length comprised between 4m and 14m (roof-mounted installations)**

- For ground-mounted installations:
  - one (1) meter above any part of the PV array

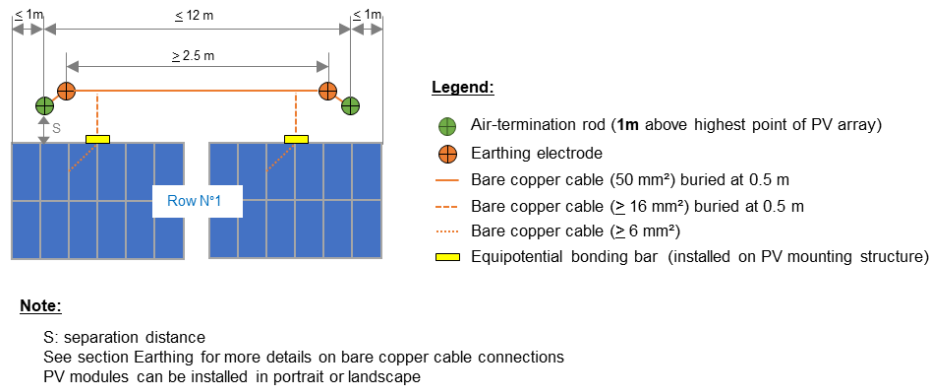

**Figure 2-6: LPS design for PV array length comprised between 4m and 14m (ground-mounted installation)**

- The distance between the two air-terminal rods along the same row shall be maximum 12 meters. The first and the last air-terminal rods shall have a distance from the edge of the row (first and last PV module) not more than 1 meter. In case this is not possible to achieve ( $L > 14$  m), additional air-terminal rod(s) shall be placed in between.

- **Case 2:** L is less than 4 meters ( $L \leq 4m$ )
  - **One air-terminal rod** shall be installed as minimum for each row of the PV array. The air-terminal rod shall have a total length sufficient to have the top part standing **two (2) meters** above any part of the PV Array. The rod shall be installed at equal distance from the extremities of the PV array.

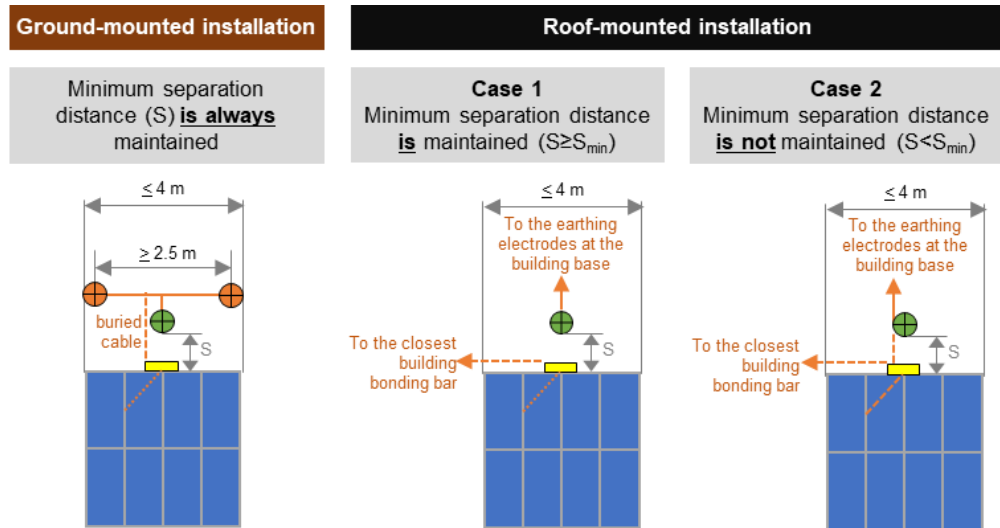

**Legend:**

- Air-termination rod (**2m** above highest point of PV array)
- ⊕ Earthing electrode
- Bare copper cable ( $50 \text{ mm}^2$ ) – down conductor – buried at 0.5 m for ground-mounted installations
- - - Bare copper cable ( $\geq 16 \text{ mm}^2$ ) – buried at 0.5 m for ground-mounted installations
- ⋯ Bare copper cable ( $\geq 6 \text{ mm}^2$ )
- ▬ Equipotential bonding bar (installed on PV mounting structure)

**Note:**

- S: separation distance
- See section Earthing for more details on bare copper cable connections
- PV modules can be installed in portrait or landscape

**Figure 2-7: LPS design for PV array length lower or equal to 4m**

As alternative (not showed on Figure 2-7), it is also acceptable to install **two air-terminal rods** as minimum for each row of the PV array. With two air-terminal rods, the air-terminal rods shall have a total length sufficient to have the top part standing **one (1) meter** above any part of the PV Array mounting structure. The rods shall be installed at the two extremities of the PV array.

### 2.5.1.4 Other recommendations

- Due to the inductive coupling of interference, it is advisable to install PV combiner boxes (if any) as far as possible from air-terminal rod(s) but still under the PV modules on the mounting structure;
- In case of a two-row (or more) configuration, a sufficient distance shall be kept between the rows to avoid that the air-terminal rod causes core shadows on the PV array;
- Earth-termination system shall be installed in such a way to reach an earth resistance **below 10 Ohms**.

## 2.5.2 Technical Requirements

### 2.5.2.1 Air-termination system

- The air-terminal rod(s) shall be installed on a separate concrete base as a free-standing mast. It can also be installed and fixed on the PV mounting structure by mean of with insulating support/spacer holders made of glass-fibre reinforced plastic (diam. 16 mm and material factor  $k_m = 0.7$ ), as illustrated on Figure 2-3 and Figure 2-4;
- The separation distance (S) shall be kept as per the requirements described in **2.5.1.2**;
- The tip of the air-terminal rod shall stand with a minimum height above the highest point of the PV mounting structure as per requirements described in section **2.5.1.3**;
- The quantity of air-terminal rod(s) to be installed is depending on the length L of the PV array and shall be as per requirements described in section **2.5.1.3**;
- The material of the air-terminal rod shall be Aluminium. The minimum thickness of the 1-meter top part shall be 10 mm. Larger diameters shall be used for the lower parts of the air-terminal rods. The rod shall be rated to withstand 200kA standard lightning impulse;
- The air-termination system shall have as few joints in it as possible. Where joints are necessary, they shall be mechanically and electrically effective and shall be so made as to exclude moisture completely. The joints may be clamped, screwed, bolted, crimped, riveted or welded. With overlapping joints, the length of the overlap should not be less than 20 mm for all types of conductors;
- The upper extremity of the air-terminal rod(s) shall be pointed for better caption of lightning. Air-termination tip in ZDC material can be used for sealing the ends of air-terminal rod(s);
- The air-termination system shall have no moving parts and will have no dependence on external power supply or batteries;
- The air-terminal rod shall allow at its lower extremity a direct connection of the rod to the earth-termination system via a bare copper cable of minimum 50 mm<sup>2</sup> cross section (down conductor). This direct connection shall be made with the use of compression lug (or equivalent);
- If not specified different, all accessories of the air-termination system shall be made of stainless steel. When two different materials are in contact (i.e. air-terminal rod and fixation accessories

for support, air-termination tip and rod itself) it shall be insured that compatible material shall be used to avoid galvanic corrosion.

### 2.5.2.2 Down conductor

- The down conductor consists of a bare copper conductor of 50 mm<sup>2</sup> cross section connecting the lower extremity of the air-terminal rod to the earthing electrode of the earth-termination system:
  - At ground level, this cable shall be buried at 0.5 meter, unless the earthing electrode is adjacent to the air-terminal rod (for ground-mounted installation only)
  - For rooftop installation, the down conductor shall be installed in such a way that the distance to the earth-termination system is kept to a minimum and shall be fixed to the building structure with roof- and wall- mounted conductor holders of stainless steel material (min. 2 mm thickness). The bare copper down conductor shall be installed within PVC pipe for the last three meters above ground, in order to protect persons from accidental touch and to mechanically protect the down conductor
- Connection shall be done with the use of copper compression lug, as per requirement mentioned in section 2.5.2.5, especially with regard to anti galvanic corrosion measures.

### 2.5.2.3 Earth-termination system

The earth-termination system shall be installed so that the final earth resistance (resistance between the earth-termination system and the ground) does not exceed **10 Ohms** (low frequency measurements).

Keeping the above value of resistance as main objective of the earth-termination system, following minimum requirements shall also apply:

- For ground-mounted installations, at the foot of each air-terminal rod, one earthing electrode shall be installed with its own inspection pit. This earthing electrode shall be connected to the other earthing electrode(s) of the system with a bare copper conductor (minimum cross section of 50 mm<sup>2</sup>) buried at a depth of 0.5 meter;
- For roof-mounted installations, each air-terminal rod shall be connected through down conductors to the earthing electrodes to be installed at the base of the building (at ground level), each with its own inspection pit. As minimum, two earthing electrodes shall be installed preferably at the opposite side of the building. Each earthing electrode at the base of the building, shall be connected to the other earthing electrode(s) of the system and to the building bonding bar with a bare copper conductor (minimum cross section of 50 mm<sup>2</sup>) buried at a depth of 0.5 meter;
- The length of each earthing electrode shall not be less than 2.5 meters;
- At least two earthing electrodes shall be placed (even for small PV array requiring only one air-terminal rod). The distance between the earthing electrodes shall be not lower than the length of the electrode itself (i.e. 2.5 meters);
- Earthing electrodes shall be of Pipe-in-Pipe technology;

- Earthing electrodes shall be made of copper or of hot dipped galvanized iron. The hot dipped galvanization of the earthing electrodes shall be 70 microns to 100 microns;
- Earthing electrodes shall not have an outer diameter less than 48 mm and an inner diameter less than 27;
- To install the earthing electrode, a hole of minimum 100 mm (or as per manufacturer recommendations) diameter shall be dug for the length of the electrode. Certified low resistivity earth enhancement material shall be used to fill the hole with the electrode. The earth resistivity enhancement material shall be not less than 30 kg for each earthing electrode;
- Earthing inspection pit of each earthing electrode shall be made of solid concrete with minimum dimension of 320 mm x 320 mm x 320 mm. Cover shall be marked with word “EARTH” or acceptable earthing marking.

### 2.5.2.4 Surge Protection Devices (SPD)

In case of a lightning strike to the external LPS, high voltage impulses are induced on all electrical conductors and partial lightning currents flow into all sort of cables (DC and AC if any). Surge Protective Devices (SPDs) must be installed to protect the electrical components.

SPDs shall provide an overvoltage protection for the PV modules, the solar charge controller and the inverter. There are two types of SPD: Type 1 and Type 2. SPD Type 1 have the capability to carry lightning currents of 10/350  $\mu$ s wave form without destructing the equipment and protects against direct lightning strikes. SPD Type 2 is characterized to withstand 8/20  $\mu$ s current wave form and aims to prevents the spread of overvoltage spikes. Combined Type 1+2 is a single device which combines both protections of Type 1 and Type 2. The selection of SPD type depends on the overall LPS design. Figure 2-8 presents the SPD locations and characteristics depending on the installation configuration.

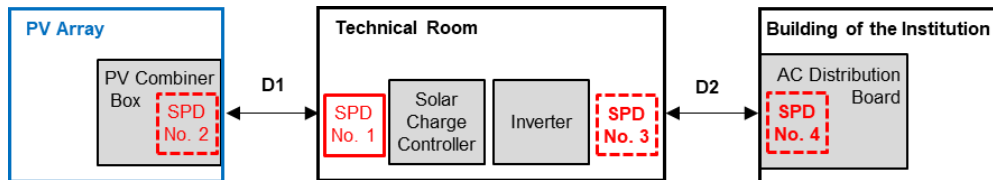

D1: distance between DC Combiner Box (at PV Array) and the Solar Charge Controller  
 D2: distance between the Technical Room (inverter) and the building where the AC distribution board is installed

**Legend:**

- - - SPD required under certain conditions only – see below table
- SPD always required

SPD No.	Current	Required	SPD type	
			Case 1 Minimum separation distance <u>is</u> maintained	Case 2 Minimum separation distance <u>is not</u> maintained
SPD No. 1	DC	Always	Type 2	Combined Type 1+ 2
SPD No. 2	DC	Only if D1 > 10 meters		
SPD No. 3	AC	Only if D2 > 10 meters		
SPD No. 4	AC	Only if D2 > 10 meters		

*Note: SPD No. 3 and No. 4 are **not required** if the Technical Room (Solar Charge Controller and Inverter) are installed in the **same building** of the Institution where the AC Distribution Board is installed*

**Figure 2-8: SPD requirements (location and type)**

The following table presents the minimum SPD requirements regarding nominal discharge current and impulse current.

**Table 2-2: SPD characteristics**

Type	Minimum current requirements
<b>Type 2</b>	8/20 $\mu$ s wave form: - Nominal discharge current $I_n \geq 5$ kA - Maximum discharge current $I_{max} \geq 20$ kA
<b>Type 1+2</b>	8/20 $\mu$ s wave form: - Nominal discharge current $I_n \geq 5$ kA Maximum discharge current $I_{max} \geq 20$ kA  10/350 $\mu$ s wave form: - Lightning impulse current $I_{imp} \geq 12.5$ kA

The following additional requirements apply:

- SPD No. 1 and No.2 (when applicable) shall be suitable for Direct Current and specific to PV application compatible with the voltage range and rating of the PV array:
  - $U_p$  (voltage protection level) shall be at least 20% lower than the rated impulse withstand voltage ( $U_w$ ) of the equipment to protect
  - $U_c$  (maximum continuous voltage) shall be 20% more than open circuit voltage of the PV array
  - $I_{scpw}$  (short circuit current rating) shall be more than the maximum current which can be delivered by the PV array (more than short circuit current  $I_{sc}$  of the PV array)
- SPD shall have visual status indication;
- SPD shall be compatible in mounting on DIN Rail Channel;
- The earthing cable for the SPD shall be connected to the equipotential bonding bar located at PV array for SPD No. 2, at the technical room for SPD No.1 and SPD No.3 and at the building bonding bar for SPD No. 4 and shall be of copper with a minimum cross section of:
  - 6 mm<sup>2</sup> if the minimum separation distance has been maintained
  - 16 mm<sup>2</sup> if the separation distance could not be maintained
  - Other earthing connections are described at paragraph 2.5.3
- All cables must be routed in such a way that large conductor loops are avoided;
- AC SPD shall be compliant with IEC 61643-11 and DC SPD with EN 50539-11.

### 2.5.2.5 Lugs

- The material of the lugs used to connect air-terminal rods and earthing electrodes with down conductors and earthing cables shall be copper in order to avoid galvanic corrosion due to the interaction of different materials;
- If due to manufacturing limitations, it cannot be avoided to have two different metals in contact at an electrical connection, the use of bi-metallic washers or equivalent galvanic corrosion mitigating measures shall be used;
- Earth entries in the ground made of galvanized steel material must be protected against corrosion over a distance of at least 0.3 meter above and below the surface of the earth. Generally, bituminous coatings are not sufficient. A moisture proof sheath, e.g. butyl rubber strips, heat-shrinkable sleeves or preferably stainless steel, provides protection.

### 2.5.3 Earthing

- All electrical equipment and metallic structure of the PV array, including mounting structures, shall be connected to the earth-termination system to form an equipotential system;
- The connection of the PV mounting structure to the earth shall be established at the lower level of the mounting structure, by means equipotential bonding bar(s) installed on the PV mounting structure. Each sub-array shall have its own equipotential bonding bar, as shown on Figure 2-5, Figure 2-6 and Figure 2-7. Each equipotential bonding bar installed on the PV mounting structure bar shall be connected:
  - to the metallic part of the PV mounting structure with bare copper conductors of minimum cross section of:
    - 6 mm<sup>2</sup> for ground mounted installations or for roof-top installations when the minimum separation distance could be maintained
    - 16 mm<sup>2</sup> for roof-mounted installation when the minimum separation distance could not be maintained
  - to the earth-termination system with bare copper conductors of minimum cross section of 16 mm<sup>2</sup> by connection to:
    - the earthing electrodes or to the buried 50 mm<sup>2</sup> bare copper conductor connecting the earthing electrodes for ground-mounted installations
    - the closest down conductor for roof-mounted installations (the down conductor is then connected to equipotential bonding bar of the building)

Earthing connections are summarized on Figure 2-9.

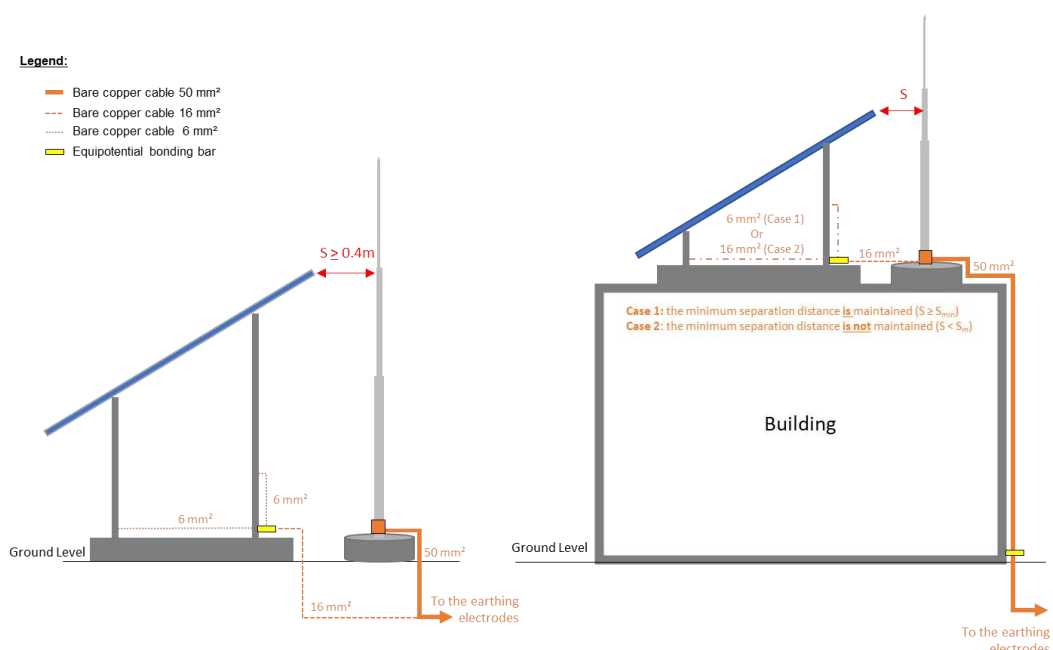

**Figure 2-9: Earthing requirements**

- All earthing electrodes shall be connected together by a bare copper conductor of 50 mm<sup>2</sup> cross section buried at least at 0.5 meter depth;
- In the technical room where the solar charge controller and the inverter are installed, an equipotential bonding bar shall be installed (wall-mounted) and connected to the earth-termination system with a bare copper conductor or yellow/green cable of at least 16 mm<sup>2</sup>;
- The metallic structure of the solar charge controller and the inverter shall be connected to the technical room equipotential bonding bar with a minimum cross section of:
  - 6 mm<sup>2</sup> for ground mounted installations or for roof-top installations when the minimum separation distance could be maintained
  - 16 mm<sup>2</sup> for roof-mounted installation when the minimum separation distance could not be maintained
- For ground-mounted installation, a bare copper conductor of 50 mm<sup>2</sup> cross section shall be buried between the PV array and the technical room and connected to the earth-termination system of the building;
- The equipotential bonding connections shall be made as direct and straight as possible.

## 2.6 Installation

The installation shall follow for the applicable parts the Electrical Design Requirements for public buildings, which is part of the National Building Code (NBC 207:2003).

### 2.6.1 General

- All components shall be installed according to manufacturer instructions;
- The Installation Company is required to coordinate with the Institution, AEPC and its representatives, financing institutions and other relevant stakeholders during the installation (when required);
- Inverter and SCC shall be installed next to each other and the distance to the battery bank shall be kept as minimum as possible;
- Preferably, all components shall be installed in one dedicated separate technical room provided that i) a safety clearance of minimum 0.5 meter is observed between the battery bank and any electrical device (SCC and inverter) and ii) the technical room is not a confined area and is ventilated according to the battery manufacturer recommendation. A recommended configuration consists in installing the battery bank in an adjacent room on the other side of the wall where the inverter and SCC are installed. In all cases, the battery and technical rooms shall be ventilated as per recommendations of the component manufacturer to prevent the formation of an explosive hydrogen concentration (mainly applicable for flooded lead acid batteries). The ventilation shall also ensure an ambient temperature compatible with operating range of the different components. This technical room shall be locked and clearly identified with specific label on the door.
  - In case, it is not possible to dedicate a technical room for the system due to the building arrangement, the components shall be installed in a room where the presence of Institution staff is limited to short periods of time. In all cases, this installation room shall have sufficient ventilation and the room shall have a secure access (lockable door) and a label on it indicating the presence of the system.
- The following warning stickers shall be installed in the room where the components are installed (especially close to the battery bank)



**Figure 2-10: Warning stickers to be installed close to the battery bank in the technical room**

- The installation shall be free of any major defects. A system will be considered to have major defects, if there is:
  - Broken, cracked, bent, misaligned or torn external surface of any component (PV module, battery, charge controller, inverter, other balance of system components)
  - Loss of mechanical integrity, to the extent that the installation and/or operation of the system would be impaired
  - Browning of any printed circuit boards
  - Signs of overheating and corrosion
  - Electrolyte leakage from the batteries
  - Deterioration of wiring insulation
  - Failure to function any component
- A permanent sticker with the name and contact details (phone number and email) of the Installation Company and the date of the system commissioning shall be fixed visibly on one of the key components in the technical room;
- A permanent sticker with all instructions to safely shut down the system (isolating PV array and battery bank) shall be fixed to the wall in the vicinity of the SCC and inverter.

## 2.6.2 PV Array

- The PV array can be installed either on the ground or on the roof. The location of the PV array shall be decided jointly between the IC and the Institution:
  - PV array installation shall be made in such a way that PV array is accessible for regular cleaning and maintenance
  - PV array installation shall be in area free of potential shading from trees or any other obstacles (as much as possible), slopped with optimum tilt of **30°** and oriented towards the **South**
  - PV modules shall be installed according to recommendations from the manufacturer described in the installation manual and shall respect a minimum space (e.g. 1 to 2 cm) between adjacent modules
- In case rooftop installation, the following conditions shall be verified:
  - the roofing surface is in good conditions
  - the roof structure is solid/resistant enough to bear the weight of the system
  - the roof is accessible with a secure access
  - in case of inclined roof, it is possible to correct the inclination and orientation of the PV array to 30° tilt towards the South

- the space is sufficient, including a secure path of 1 meter all around the PV array to ensure operation and maintenance activities
- A minimum space (preferably 20 cm but at least 15 cm) between the PV module rear side and the roof surface to allow natural ventilation and cooling of the PV modules
- Mounting structure and foundations:
  - The PV mounting structure (ground-mounted or roof top) shall be made of aluminium or hot dip galvanized steel with a minimum coating thickness of 70 µm
  - All fastening accessories (including screws) shall be made of aluminium or stainless steel (SAE 304). The design lifetime of the mounting structure shall be 20 years
  - If installed on the roof, the anchorage system of the mounting substructure on the roof shall be performed without drilling the roof slab or any other method injuring the waterproofing layer of the roof. The Installation Company shall implement during the works all the necessary measures to maintain the water tightness of the roof
  - If PV array is installed at ground level, concrete foundations shall be used, and an appropriate fence with barbed wire shall be installed all around the PV array to prevent any unauthorized persons to enter the PV array area. A warning sign regarding electrical hazard shall be fixed on the fence around the PV array.
  - If PV array is installed at ground level, the mounting structure shall have a minimum necessary clearance distance between ground level and bottom edge of PV modules of **0.5 meter**
  - If PV array is installed on a flat roof (with an inclined mounting structure), the mounting structure shall have a minimum necessary clearance distance between roof level and bottom edge of PV modules of **0.2 meter** (and a maximum of 0.5 meter)
  - The mounting structure and foundations shall be designed to withstand **180 km/hr** wind speed. Calculation note shall be provided with project documentation
- PV connectors:
  - The connectors used to form PV strings shall be compatible with the original PV module connector. Only the connector type approved by the module manufacturer shall be used and it shall be designed according to maximum current in the circuit
  - All PV connectors shall be suitable for outdoor installations at site condition with minimum protection of IP65 according to IEC 60529
- One PV combiner box shall be installed at the PV array to connect the different strings in parallel. The box shall be suitable for outdoor installation, shall be protected from direct sunlight and rain during installation and shall be rated minimum IP65 according to IEC 60529. In addition, the PV combiner box shall:
  - include a DC disconnect switch (isolation switch to isolate the PV array from the SCC) and a SPD if distance to the SCC is more than 10 meters (see more details in section 2.5.2.4)

- include fuse holders and fuses for each string If the PV array is composed of more than 2 strings. Fuse ratings shall be selected according to PV module manufacturer's recommendation on reverse current limit
- have a mechanical protection for all live components to avoid a direct electrical contact by the personal
- have all cable entering/outings into/from sealed properly so that dust and insects, mice cannot enter the box
- have lockable door with a warning sticker for electrical hazard and must be easily accessible

### **2.6.3 Battery bank**

- Flooded lead acid batteries can be supplied charged or dry with the appropriate container of electrolyte. Electrolyte spillage shall be prevented during transportation and installation;
- The battery bank shall be designed with battery terminals cover which allow maintenance whilst minimizing exposure to live parts;
- The battery shall be protected against overcurrent by fuse(s) located as close as possible to the battery terminal(s):
  - Fuses shall be rated as per the conductor size and per the component they are protecting as specified by the manufacturer;
  - Fuses shall be marked with rated current, voltage and current type (AC or DC);
  - Battery fuses shall be rated for DC service in DC applications and suitable for the system voltage of the system.
- Battery system shall be installed on suitable battery racks in a dedicated technical room or enclosure which shall provide sufficient ventilation to prevent the formation of an explosive hydrogen concentration (see more details in section 2.6.1).

### **2.6.4 Cables**

- PV string cables shall:
  - be specific for PV application with double insulation layers
  - not be exposed to direct sun and shall be UV resistant and be suitable for outdoor installation, both, underground and above ground
  - be fixed (tied) with the mounting structure and shall not be hanging and connection shall not be in tension
- Cables shall be selected with an insulation voltage level applicable to the system voltage for which they are used and ampacities suitable for the load being served;
- DC cable between battery terminals and SCC shall be single core and have a double insulation layer;

- Cables shall not be hanging at any part of installation and shall be mechanically protected. Internal house wiring shall be according to best practice and cable routing and fixing shall be neat and clean;
- If installed underground, the cable shall be placed in conduits for mechanical protection and conduits shall be protected from entering insects/animals, water, dirt i.e. the opening ends shall be closed;
- All cables shall be permanent labelled properly indicating the polarity;
- AC cables shall have three conductors (one for the neutral, one for the phase, one for the earthing) and be sized according to the load to be supplied on the circuit, the Miniature Circuit Breakers (MCB) rating and the maximum admissible cabling loss as per Table 2-3. Minimum standard sizes of wiring cable are as follows (item 5.10 of the Nepalese Standard):
  - Light Circuit: 2.5 mm<sup>2</sup> - PVC insulated copper stranded cable
  - Power Circuit: 4.0 mm<sup>2</sup> - PVC insulated copper stranded cable
- Cable size shall be defined according to maximum cabling losses indicated in Table 2-3. Although, the table includes recommendations on the cross-sections to be used according to distance and voltage conditions, it is under the IC responsibility to select the final suitable cable size in order to verify the maximum cable loss. A calculation note shall be provided in the project completion report to be prepared by the IC.

**Table 2-3: Maximum values of cabling losses (1 kWp system)**

Type of cable	Maximum cabling loss	Proposed and recommended cross-section cables	
AC cable between inverter output and AC distribution board	3%	As per minimum cross section above and cable length	
DC cable between the battery bank and the inverter/SCC	1%	24 V System	48 V DC System
		Minimum 35 mm <sup>2</sup> up to a cable length of 2 meters Minimum 50 mm <sup>2</sup> up to a cable length of 3 meters	Minimum 16 mm <sup>2</sup> up to a cable length of 4 meters Minimum 25 mm <sup>2</sup> up to a cable length of 6 meters Minimum 35 mm <sup>2</sup> up to a cable length of 8 meters
DC cable between PV Array and SCC	3%	40V < PV Array mppt voltage < 60V	60V < PV Array mppt voltage
		Minimum 10 mm <sup>2</sup> up to a cable length of 10 meters Minimum 16 mm <sup>2</sup> up to a cable length of 16 meters	Minimum 10 mm <sup>2</sup> up to a cable length of 20 meters
		Minimum 25 mm <sup>2</sup> up to a cable length of 25 meters	

## 2.6.5 Building internal electrical installation

The installation shall follow the Electrical Design Requirements for public buildings, which is part of the National Building Code (NBC 207:2003), as provided in Annex B.

The building electrical installation shall include:

- An AC distribution board containing:
  - a main switching device including protection against residual current to the earth (differential protection 30 mA) such as a Residual Current Circuit Breaker. This switching device shall be clearly identified as it serves as emergency switch when needed
  - MCB for each AC electrical circuit. Each circuit shall be identified with permanent label
  - Rating of the main switching device and MCB shall be selected according to the loads to be supplied on the circuits
  - An AC SPD in case the inverter is installed in a technical room which is located more than 10 meters from the building where the AC distribution board is installed (see more details in section 2.5.2.4)
  - An equipotential bonding bar connected to the earthing system to ensure same potential for all connections to the earthing equipotential conductor
- Each light shall be equipped with its own lamp socket and ON/OFF switch, with the minimum requirements as follows:
  - For schools: each classroom and office rooms shall be equipped with one light as minimum and light shall be of WLED with rating of 10 W each
  - For health posts: each examination room, delivery room and office room shall be equipped with one light as minimum and light shall be of WLED with rating of
    - 10 W each for all other rooms
    - 15 W for delivery room, and
    - Minimum one (1) outdoor light shall be installed as minimum
- Two power sockets for each room hosting electrical appliances.

## 3 TESTING AND COMMISSIONING

The testing and commissioning activities shall be performed by the Installation Company and witnessed by AEPC Representative (AEPC/Outreach Centre/Independent Consultant) and the Institution representative as per the Testing and Commissioning Form provided in Annex C.

The Testing and Commissioning report shall be prepared based on the form provided in Annex C and signed by the Installation Company, AEPC representative and the Institution.

During the site inspection, it will be verified whether the system has been implemented as per the approved design and as built design documentation. In case of any defects in material, installations, safety, performance and operations of IC's scope observed during the testing and commissioning, the IC shall be responsible to take necessary actions for improvements.

## 4 MINIMUM SPARE PARTS AND TOOLS

The IC shall provide the following minimum spare parts and tools to the Institution immediately upon the successful completion of testing and commissioning requirements.

**Table 4-1: Spare parts and tools – to be provided by the Installation Company**

Items	Quantity
PV array cable	10 m
Battery cable	5 m
AC cable	10 m
PV connector	2 pair (male+female)
PV string fuses	5
Battery fuse	3
Adjustable Wrench	2
Screw Driver Set	1 set
Handheld Multimeter	1
Demineralized water	15 litres
Hydrometer (to measure electrolyte density)	1
Set of protective glasses and gloves to be used when manipulating acid from the battery.	1

The IC can use the spare parts and tools during warranty period, however it shall immediately be replenished at its own cost. This will be verified by AEPC Representative (AEPC/Outreach Centre/Independent Consultant) at the end of the warranty period.

## 5 DOCUMENTATION

### 5.1 On-site Documentation

As built documentation and operational manual shall be prepared and handed over to the Institution at the commissioning phase and explained during the training session.

The minimum documentation to be supplied by the IC before the testing and commissioning activities shall consist of:

- Operation and Maintenance (O&M) manual for the system in English and in local language with clear information on preventive maintenance, frequency of maintenance and procedure of maintenance, including a troubleshooting section, clear explanations on displayed status information and alarms, procedure with programming steps in case of system reset and list of spare parts and tools present on site at testing and commissioning. The O&M manual shall clearly mention the contact details (phone number, email) of the responsible person from the IC to be contacted in case of problems during the warranty period;
- Technical folder: which shall include the following:
  - Name and contact details of the IC, date of the installation and date of the testing and commissioning
  - Design summary with installed capacities and component references
  - As-built drawings of the system including layout and wiring and connection diagram
  - Component documentation from the original manufacturer for each key document (at least for PV module, inverter, battery and SCC): data sheet, certificates (IEC, PIT, RST, as applicable) or manufacturer statement (as per requirements), installation manual, user manual and warranty documents
  - Calculation notes confirming the suitability of:
    - the proposed design for the PV array foundations and mounting structure
    - the different cable cross-sections according to maximum cable losses

This documentation shall be available on site as hard copy and also as soft copy (CD or USB stick).

## 5.2 Project Completion Report

Once, the system is installed and ready to be commissioned and tested, the IC shall prepare a Project Completion Report, which shall include information from the Technical Folder as described in 5.1 and pictures of the installation. Project Completion Report shall include all RST certificates.

The Project Completion Report shall be provided to the Institution and is required as an attachment to the Subsidy Application Form which is to be prepared by the Institution.

## 6 TRAINING

At least two persons from the Institution shall be trained by the Installation Company before the testing and commissioning stage.

- The training topics shall cover the minimum topics that are defined in the operation and maintenance manual;
- The training shall also include practical aspects of project and trainee shall be trained practically on how to verify proper functioning of each components (PV module, SCC, inverter and battery);

- The trainee shall be shown practically at project site on how to perform scheduled maintenance activities, Emergency Shut down procedures, Do and Don't included in the O&M manual;
- Upon the completion of the training, the IC shall issue a training certificate to trainees, which shall be further signed by the Institution's representative and the trainees.

## 7 WARRANTY

The ISPS must be guaranteed by the IC against any manufacturing/ design/ installation defects for a minimum period of 2 years. The IC must supply a Warranty Card containing the details of the system supplied.

During the warranty period, AEPC will have all the rights to cross check the performances of the ISPS. AEPC may carry out the frequent inspections of the system installed and randomly pick up its components to get them tested at any test centre. If during such tests any part is not found to be as per the specified technical parameters, AEPC will take the necessary action. The decision of AEPC in this regard will be final and binding to the IC.

The table below summarizes the minimum requirements for the manufacturer product warranty duration. In addition, PV modules shall be warranted by the manufacturer for their rated output, with a minimum of 90% at year 10 and a minimum of 80% at year 25.

**Table 7-1: Product warranty for the major components**

Component	Minimum Duration
PV module (up to 150 Wp) against design and manufacturing defects	5 years
PV module (above 150 Wp) against design and manufacturing defects	10 years
Battery	3 years
Inverter	3 years
Solar Charge Controller	3 years

## 8 AFTER SALES SERVICE

The IC shall provide the after sales service during the warranty period which shall include minimum:

- The IC shall repair/replace or rectify of all defects at its own cost (including transportation to the site when necessary), at the most within fifteen (15) days from the receipt of complaint(s) from the Institution or AEPC representatives:
  - Such repaired and replaced material shall be of same model, same type and same technical characteristics as provided by the IC during the first installation of the ISPS
  - The IC shall provide the warranty on newly repaired/replaced component which in overall covers at least the same warranty duration, in total, of original component

- All the non-functional parts/materials/items replaced during the warranty period shall be the property of the IC and shall be safely removed from the site
- In case of warranty claim of components after the warranty period, the IC shall assist the Institution in his best way for a warranty claim;
- The IC shall make all necessary arrangements for satisfactory operation, maintenance and performance of the ISPS during the warranty period;
- The IC shall take complete responsibility for preparing and verification of any claim on Institution's behalf that may arise due to underperformance and defects of components covered under warranty;
- The IC shall ensure that sufficient spare parts of all components (PV module, SCC, inverter and battery) provided under the scope of the IC will be made available during the case when project requires replacements/repairs, during the warranty period;
- The IC can use the initial spare parts and tools during the warranty period, however, shall immediately be replenished at its own cost.

## **9 ENVIRONMENTAL AND SOCIAL MANAGEMENT PLAN (ESMP)**

The IC shall comply with applicable Environmental and Social Management Plan provided in Annex D as a part of its scope of work.

## 10 ANNEXES

### 10.1 Annex A: Bidder's Technical Form (to be completed by the Bidder)

**Bidder to note that the verification of all information and document provided within the Bidder's Form will also be verified during testing and commissioning by AEPC or its representative.**

System overview and design summary	
<b>Bidder Name</b>	
<b>Institution Name</b>	
<b>Total PV array (Wp)</b>  Quantity and unit rated power of PV modules  PV module manufacturer and model	
<b>Total battery bank capacity (Wh - C10)</b>  <b>Battery bank voltage (24V or 48V)</b>  Lead acid technology  Quantity and unit battery capacity (Ah in C10 and V)  Battery manufacturer and model	<input type="checkbox"/> Flooded <input type="checkbox"/> Sealed (VRLA)
<b>Inverter output (kVA)</b>  Inverter manufacturer and model	
Solar Charge Controller manufacturer and model	
<b>Installation type</b>	<input type="checkbox"/> Ground-mounted <input type="checkbox"/> Rooftop
<b>The proposed design and components are fully compliant with the Technical Specifications</b>	<input type="checkbox"/> yes <input type="checkbox"/> no

Minimum Technical Requirements – 1 kWp system				
Bidder Name				
Institution Name				
Item	Component	Minimum Key Requirements	To be completed by the Bidder	
			Offered	Compliant
1	Solar PV array	$\geq 1,000$ Wp		<input type="checkbox"/> yes <input type="checkbox"/> no
2	PV module	Manufacturer: Model:		
		Unit peak power (P) $\geq 100$ Wp		<input type="checkbox"/> yes <input type="checkbox"/> no
		Crystalline silicon technology		<input type="checkbox"/> yes <input type="checkbox"/> no
		Efficiency $\geq 15\%$ (only if P $\geq 250$ Wp only)		<input type="checkbox"/> yes <input type="checkbox"/> no <input type="checkbox"/> N/A
		Power tolerance: 0 – 5% max		<input type="checkbox"/> yes <input type="checkbox"/> no
		Junction Box is at least IP65		<input type="checkbox"/> yes <input type="checkbox"/> no
		Certified compliant with IEC 61215 and IEC 61730 by an independent accredited laboratory	Evidence Provided: <input type="checkbox"/> yes <input type="checkbox"/> no	<input type="checkbox"/> yes <input type="checkbox"/> no
		Manufacturer with at least 5 years experience and certified ISO 9001 and ISO 14001	Evidence Provided: <input type="checkbox"/> yes <input type="checkbox"/> no	<input type="checkbox"/> yes <input type="checkbox"/> no
		Warranty of rated output $\geq 90\%$ at year 10 $\geq 80\%$ at year 25		<input type="checkbox"/> yes <input type="checkbox"/> no
3	Solar Charge Controller (SCC)	Manufacturer: Model:		
		DC Input $\geq 1,400$ Wp		<input type="checkbox"/> yes <input type="checkbox"/> no
		Type	<input type="checkbox"/> MPPT <input type="checkbox"/> PWM	<input type="checkbox"/> yes <input type="checkbox"/> no
		In-built controller within the inverter	<input type="checkbox"/> yes <input type="checkbox"/> no	N/A
		Compliant with applicable requirements of IEC 62109 and IEC 62509 (certificate by an independent accredited laboratory OR statement from the manufacturer)	Evidence Provided: <input type="checkbox"/> yes <input type="checkbox"/> no	<input type="checkbox"/> yes <input type="checkbox"/> no
		Manufacturer with at least 3 years experience and certified ISO 9001 and ISO 14001	Evidence Provided: <input type="checkbox"/> yes <input type="checkbox"/> no	<input type="checkbox"/> yes <input type="checkbox"/> no
		At least IP 21		<input type="checkbox"/> yes <input type="checkbox"/> no

Minimum Technical Requirements – 1 kWp system				
Bidder Name				
Institution Name				
Item	Component	Minimum Key Requirements	To be completed by the Bidder	
			Offered	Compliant
		Display function (voltage, state of charge, currents and alarm)		<input type="checkbox"/> yes <input type="checkbox"/> no
		Reverse polarity protection, overtemperature protection and reverse current protection at night		<input type="checkbox"/> yes <input type="checkbox"/> no
		Compatibility of voltage range with battery recommendations		<input type="checkbox"/> yes <input type="checkbox"/> no
		Product warranty $\geq$ 3 years		<input type="checkbox"/> yes <input type="checkbox"/> no
4	Battery	Manufacturer: Model:		
		Total battery bank capacity $\geq$ 7,200 Wh (C10)		<input type="checkbox"/> yes <input type="checkbox"/> no
		Parallel string connection $\leq$ 4		<input type="checkbox"/> yes <input type="checkbox"/> no
		Tubular lead acid		<input type="checkbox"/> yes <input type="checkbox"/> no
		Manufacturer with at least 3 years experience and certified ISO 9001 and ISO 14001	Evidence Provided: <input type="checkbox"/> yes <input type="checkbox"/> no	<input type="checkbox"/> yes <input type="checkbox"/> no
		Self discharge shall be $\leq$ 3% per month at 25°		<input type="checkbox"/> yes <input type="checkbox"/> no
		$\geq$ 1,500 cycles at 70% depth of discharge		<input type="checkbox"/> yes <input type="checkbox"/> no
Product warranty $\geq$ 3 years		<input type="checkbox"/> yes <input type="checkbox"/> no		
5	Inverter	Manufacturer: Model:		
		Nominal Power $\geq$ 2,000 VA		<input type="checkbox"/> yes <input type="checkbox"/> no
		Pure sine wave voltage (AC output voltage of 230 V, 50 Hz)		<input type="checkbox"/> yes <input type="checkbox"/> no
		Compliant with applicable requirements of IEC 62109 and IEC 61000-6-1 and IEC 61000-6-3 (certificate by an independent accredited laboratory OR statement from the manufacturer)	Evidence Provided: <input type="checkbox"/> yes <input type="checkbox"/> no	<input type="checkbox"/> yes <input type="checkbox"/> no
		Manufacturer with at least 3 years experience and certified ISO 9001 and ISO 14001	Evidence Provided: <input type="checkbox"/> yes <input type="checkbox"/> no	<input type="checkbox"/> yes <input type="checkbox"/> no
		At least IP 21		<input type="checkbox"/> yes <input type="checkbox"/> no

Minimum Technical Requirements – 1 kWp system				
Bidder Name				
Institution Name				
Item	Component	Minimum Key Requirements	To be completed by the Bidder	
			Offered	Compliant
		Indication of status (at least with LED signals)		<input type="checkbox"/> yes <input type="checkbox"/> no
		Stand-by function and automatic load detection function		<input type="checkbox"/> yes <input type="checkbox"/> no
		Power factor from 0.5 to 1		<input type="checkbox"/> yes <input type="checkbox"/> no
		LVD, LVR and HVR values compatible with SCC and battery recommendations		<input type="checkbox"/> yes <input type="checkbox"/> no
		Product warranty $\geq$ 3 years		<input type="checkbox"/> yes <input type="checkbox"/> no
6	Mounting structure	Structure: Aluminium or Hot Dip Galvanized (minimum 70 $\mu$ m)		<input type="checkbox"/> yes <input type="checkbox"/> no
		Accessories: Aluminium/Stainless steel (SAE 304)		<input type="checkbox"/> yes <input type="checkbox"/> no
		Designed to withstand 180 km/hr wind speed and 20 years lifetime	<input type="checkbox"/> yes <input type="checkbox"/> no	<input type="checkbox"/> yes <input type="checkbox"/> no
7	Installation	As per requirements in section 2.6		<input type="checkbox"/> yes <input type="checkbox"/> no
8	Lightning Protection System and Earthing	As per requirements in section 2.5		<input type="checkbox"/> yes <input type="checkbox"/> no
9	Cables and conduits	As per requirements in section 2.6.4 (in particular maximum cabling losses as per Table 2-3)		<input type="checkbox"/> yes <input type="checkbox"/> no
10	Documentation to be provided at bidding stage with the quotation	For PV modules, SCC, inverter and battery: <ul style="list-style-type: none"> <li>- Datasheet</li> <li>- PIT (and RST if available<sup>1</sup>)</li> <li>- Compliance with relevant IEC standards (certificates by accredited laboratory or manufacturer statement, as per requirements mentioned above)</li> <li>- Evidence of manufacturer experience and track record and ISO 9001 and ISO 14001 certification</li> </ul> Technical design and drawing of the PV Mounting structure		<input type="checkbox"/> yes <input type="checkbox"/> no

<sup>1</sup> RST must be provided latest before T&C if not available at the bidding stage

## **10.2 Annex B: Electrical Design Requirements for public buildings (NBC 207:2003)**



# NEPAL NATIONAL BUILDING CODE

**NBC 207 : 2003**



## **ELECTRICAL DESIGN REQUIREMENTS for (PUBLIC BUILDINGS)**

Government of Nepal  
Ministry of Physical Planning and Works  
**Department of Urban Development and Building Construction**  
Babar Mahal, Kathmandu, NEPAL  
Reprinted : 2064



# NEPAL NATIONAL BUILDING CODE

**NBC 207 : 2003**



## ELECTRICAL DESIGN REQUIREMENTS for (PUBLIC BUILDINGS)

This publication represents a standard of good practice and therefore takes the form of recommendations. Compliance with it does not confer immunity from relevant legal requirements, including bylaws

तत्कालिन श्री ५ को सरकार (मन्त्रिपरिषद्) को मिति २०६०।४।१२ को निर्णयानुसार स्वीकृत

Government of Nepal  
Ministry of Physical Planning and Works  
**Department of Urban Development and Building Construction**  
Babar Mahal, Kathmandu, NEPAL  
Reprinted : 2064

## Preface

This code has been prepared having considered the provisions of Electricity Act 2049 and Electricity Rule 2050 up to date. This includes general guidances for Electrical wiring installation. Prevention of short-circuiting has been emphasized. Utmost importance should be given in the installation of electrical wiring while preplanning and exchanging information among all concerned agencies from the earlier stages of the building works. Due to the limited technical manpower the country's construction industry, the code has been simplified for the ease of use and implementation. It is hoped that with the development of the manpower and modernization of construction processes, it will be possible to release more sophisticated set of electrical wiring installation guidelines in future.

Principal input to this code came from :

Mr. Purna P. Kadariya , DG, DUDBC

Mr. Kishore Thapa, DDG, DUDBC

Mr. Mani Ratna Tuladhar, Sr. Div. Engineer, DUDBC

Mr. Jageshwar Mahaseth, Electrical Engineer, DUDBC

Mr. Kalu Bhattarai, Electrical Engineer, Dept. of Electricity Development, New Baneswor

Mr. Ladhu Ram Tamang, General Secretary, SEEN

Mr. Amrit Man Tuladhar, Engineer, DUDBC

## TABLE OF CONTENT

<b>S.NO.</b>	<b>Particulars</b>	<b>Page No.</b>
1	1. General Requirement	1
2	2. Power Factor Improvement in Consumer's Installation	1
3	3. Planning of Electrical Installation	1
4	4. Distribution of Supply & Cabling	3
5	5. Rating of Cables & Equipment	5
6	6. Wiring	6
7	7. Earthing	9
8	8. Inspection and Testing of Installation	10
9	9. Lightning Protection of Building	12
10	10. Telecommunication and other services	12

## **1. General Requirements**

- 1.1 The installation shall generally be carried out in conformity with the Electricity Act 2049 as amended up to date and the Electricity rules 2050 framed thereunder and also the relevant regulations of Electricity supply authority concerned as amended from time to time.
- 1.2 For practices of electrical wiring, definitions, design & construction and inspection & testing of installation, IS 732, 732 (part 1) 1982, 732 (part 2) and 1982, 732 (part 3) 1982 shall be referred to respectively.

## **2. Power Factor Improvement in Consumer's Installation**

- 2.1 Condition of supply of Electricity authority or licensees stipulate the lower limit of power factor which is generally 0.8 and consumer is obliged to improve and maintain the power factor of his installation to conform to this condition
- 2.2 Execution of work: Unless otherwise exempted under the appropriate rule of electricity rules the work of and electrical installation shall be carried out by an electrical contractor licensed and under the direct supervision of a person holding a certificate of competency and by persons holding valid permit issued and recognized by the government.
- 2.3 For graphical symbols, power factor improvement, safety procedures and practices IS 8270 (Part 1) 1976 & IS 2032; IS 7752 (Part 1) 1975 & IS 5216-1969 shall be referred to respectively.

## **3. Planning of Electrical installations**

- 3.1 General – The design and planning of an electrical wiring installation involve consideration of all prevailing conditions, and is usually influenced by the type and requirement of the consumer. It is recommended that the advice of a competent electrical engineer be sought at the planning stage with a view to providing for an installation that will prove adequate for its intended purpose, and safe and efficient in its use.
- 3.2 Co-Ordination-Proper co-ordination and collaboration between the architect, civil engineer, electrical, communication and mechanical engineer shall be effected from the planning stage of the installation. The provisions that will be needed for the accommodation of substation, transformer, switchgear, service cable ducts, rising mains and distribution cables, sub-distribution boards, openings and chases in floors and walls for all required electrical installations, etc, shall be specified in advance.
- 3.3 While planning an installation, consideration should be taken of the anticipated increase in the use of electricity for lighting, general-purpose socket-outlet, kitchen heating, room heating etc.
- 3.4 Arrangement of Substation and switchgear rooms :

- a) Total Plinth (covered) Area: Electrical substations may normally be required in case of office buildings with a total plinth (covered) area of 5000 m<sup>2</sup>; even buildings with smaller plinth (covered) areas with large loading or under local regulations may require a substation. Separate substation building is generally not required if total load is less than 100 kVA. However, a suitable size of lockable space should be earmarked for installing control switchgear in buildings.
- b) Load Centre and Centre of Gravity of Buildings : The ideal location for an electrical substation for a group of buildings would be at the load centre and shall be located on the ground floor. In multi-storeyed buildings, the substation shall preferably be installed on the lowest floor level, but direct access from the street for installation or removal of the equipment shall be provided. The floor level of the substation or switchroom shall be above the highest flood level of the locality. In this case the load centre would be somewhere between the geometrical centre and the air conditioning plant room, if provided. The sub station should preferably be located in a separate building and should be adjacent to the generator room, if any. Location of substation in the basement floors should be avoided, as far as possible, In case electric substation has to be located within the main building itself for unavoidable reasons, then it should be located on ground floor with easy access from outside.
- c) Layout of Substation : In allocating the area of substation, it is to be noted that the flow of electric power is from supply company's room to HT room, then to transformer and finally to the low voltage switchgear room. The layout of the room shall be in accordance with this flow. The capacity of a substation depends upon the area of the building and its type. The capacity of transformers may be determined based on the following load requirements:

	Load Requirement Per Plinth Area (Watts/m <sup>2</sup> )
Normal lighting	20.0
Lighting with lifts, pumps but without central air-conditioning	30.0
Additional capacity for technical buildings like laboratories, hospitals, etc	11.0
Additional capacity for airconditioning	100
	(of air-conditioned area)

After calculating the electrical load on the above basis, a load factor of 70 percent is to be applied to arrive at the minimum capacity of substation. The area required for substation and transformer room for different capacities is given in standard Table.

- d) High & Low Voltage Switch Room: In case of substation having one transformer and one source of supply, the owner is required to provide one high voltage switch. In case of single point supply with two or more transformers the number of switch required will be one for incoming supply and one for each transformer. In case of duplicate supply two switches shall be provided with mechanical/electrical interlocking arrangement where necessary in cables with switches. In case the number of incoming and outgoing switches exceed five, bus coupler of suitable capacity should invariably be provided. The floor area required in case of a single switch is roughly 4mX4m and for every additional switch the length would be increased by 1m. The floor area required in respect of low voltage switchgear room may be determined keeping in view the number and type of incoming/outgoing bus coupler switches including likely expansion in future.
- e) Room For Stand By Generator: The capacity of standby generating set shall be chosen on the basis of essential light load, essential air-conditioning load, essential equipment load and essential services load, such as one lift out of the bank of lifts, one or all water pumps, etc. Having chosen the capacity and number of generating sets, a space may be provided for their installation from the Standard Table. The generating set should invariably be housed in the substation building to enable transfer of electrical load quickly as well as to avoid transfer of vibration and noise to the main building. The generator house should have proper ventilation, firefighting equipment, etc.

#### **4. Distribution of Supply & Cabling**

- 4.1 In case of connected load of 100KVA and above, the relative advantage of high voltage three-phase supply should be considered.
- 4.2 Switchgear and fuse gear shall have adequate breaking capacity in relation to the capacity of the transformers ultimately to be connected. Isolation and protection of outgoing circuits forming main distribution system may be effected by means of circuit-breakers, or fuses or switch and fuse units mounted on the main switchboard.
- 4.3 Control at point of commencement of supply: There shall be a circuit-breaker or miniature circuit-breakers or a load break switch fuse on each live conductor of the supply mains at the point of entry. The wiring throughout the installation shall be such that there is no break in the neutral wire in the form of a switch or fuse unit. The neutral shall also be distinctly marked. The main switch shall be easily accessible and situated as near as practicable to the termination of service line. On the main switch, where the conductors include an earthed conductor of a two-wire system or an earthed neutral conductor, which is to be connected thereto, an indication of a permanent nature shall be provided to identify the earthed neutral conductor.
- 4.4 Energy Meters: Energy meters shall be installed in residential buildings at such a place which is readily accessible to the owner of the building and the Authority. These should be installed at a height where it is convenient to note

the meter reading; it should preferably not be installed below one meter from the ground. The energy meters should either be provided with a protective covering, enclosing it completely except the glass window through which the readings are noted or should be mounted inside a completely enclosed panel provided with hinged or sliding doors with arrangement for locking. Energy Meter along with Switch disconnector such as MCCB, MCB & Fuse is mandatory.

- 4.5 Marking of Apparatus: Where a board is connected to voltage higher than 250 V in a three Phase system, all the apparatus mounted on it shall be marked on the following colours to indicate the different poles or phases to which the apparatus or its different terminals may have been connected:

Alternating Current	Direct Current
Three-phases-	Three-wire system-2outer wire, positive red and
Red, yellow, blue	negative blue.
1 Neutral-black	1 Neutral-black
Earth green	

Where four-wire three-phase wiring is done, the neutral cable shall be in black colour and the other three wires in red, yellow and blue.

Where a board has more than one switch, each such switch shall be marked to indicate which section of the installation it controls. The main switch shall be marked as such and where there is more than one main switch, each such switch shall be marked to indicate which section of the installation it controls. All markings shall be clear and permanent.

- 4.6 Protection against the short circuits :

- a) Cascading : Cascading is the technique by which circuit breakers with breaking capacity lower than the prospective short circuit current may be installed downstream from a current limiting type of circuit breaker. The breaking capacity of downstream breaker shall be enhanced by the limiting capability of the breaker. Combination shall be applicable to all switchgear downstream and capacity of upstream breakers should be greater or equal to the prospective short circuit current at the point of installation.
- b) Co-ordination : the characteristics of the two breakers must be co-ordinated in such a way that the energy let through by the upstream breaker shall not be more than downstream breakers. Condition for co-ordination of breakers shall be such that the downstream breaker having breaking capacity less than the prospective short circuit current, shall be permitted as long as breaker installed upstream having breaking capacity greater than or equal to prospective short circuit current at the point of installation exists.
- c) Discrimination : At the design stage of low voltage installation one must be sure that the co-ordination of automatic protecting devices like MCCB, MCB, ACB and other protective device should be selected in such a way that a fault appearing at a given point in any installation shall be cleared by the protection device installed immediately above the point of occurrence of fault. Where HRC type fuses are used for back-up protection of circuit-

breakers, or where HRC fuses are used for protection of main circuits, and circuit-breakers for the protection of sub-circuits derived therefrom, in the event of short-circuits protection exceeding the short-circuits capacity of the circuit-breakers, the HRC fuses shall operate earlier than the circuit-breakers; but for smaller overloads within the short-circuit capacity of the circuit-breakers, the circuit-breakers shall operate earlier than the HRC fuse blows.

## 5. Rating of Cables & Equipments:

- 5.1 The current-carrying capacity of different types of cables shall be chosen in accordance with good practice IS 3961-1967, 1968 and IS 1534 (part 1) 1988 shall be referred to. Cable size shall be 1.5, 2.5, 4, 6, 10, 16, shall be 1.5, 2.5, 4, 6, 10, 16, 25, 35, 50, 70, 95, 120, 150, 185, 240, 300, 400, 500 mm<sup>2</sup>.
- 5.2 The current ratings of switches for domestic and similar purposes are 5 A and 15A.
- 5.3 The current ratings of isolators and normal duty switches and composite units of switches and fuses shall be selected from one of the following values: 6, 10, 16, 25, 32, 63, 100, 160, 200, 320, 400, 500, 630, 800, 1000 and 1250 A. IS 13947-3 shall be referd.
- 5.4 The ratings of rewirable and HRC fuses shall be in accordance with good practice. IS 2086-1963 and IS 13703 shall be referred to.
- 5.5 The current ratings of miniature circuit breakers shall be chosen from the values given below: 6, 10, 16, 25, 32, 40, 63, 80 , 100, 125 A. IS 8828-1996
- 5.6 Lighting and levels of illumination: Lighting installation shall take into consideration the many factors on which the quality and quantity of artificial lighting depends. The modern concept is to provide illumination with the help of a large number of light sources not of higher illumination level. Also much higher levels of illumination are called for than in the past, often necessitating the use of fluorescent lighting suitably supplemented with incandescent fittings, where required.
- 5.7 For specific requirements for lighting of special occupancies, reference shall be made to good practice. IS 2672-1966; 4347-1967; 8030-1967 shall be referred to. Electric wiring installations in hospitals shall be done in accordance with good practice. IS 7733-1975 shall be referred to. For guidelines for electrical installation in residential buildings, reference may be made to good practice. IS 4648-1968 shall be referred to.
- 5.8 Cables: The smallest size of the cable that shall be used, will depend upon the method of laying cable, permissible maximum temperature it shall withstand, the prospective short-circuit current to which the cable may be subjected, the characteristics of the overload protection gear installed, load cycle and thermal resistivity of the soil. IS 1255-1965 shall be referred to. Short-circuit rating curves will serve as an approximate guide for selection of the size of cables.

- 5.9 Residual current breaker should be used as to avoid electrocution and fire of from electricity hazards in case of Hospital building.
- 5.10 Minimum standard size of wiring cable for light and power shall be specified as follows:
- Light circuit --- 2.5 sq.mm PVC insulated copper stranded cable
  - Power circuit - 4.0 sq.mm PVC insulated copper stranded cable.

## 6. Wiring

### 6.1 General:

- 6.1.1 Provision for Maximum Load – All conductors, switches and accessories shall be of such size as to be capable of carrying, without their respective ratings being exceeded, the maximum current, which will normally flow through them. Diversity factor shall be considered.
- 6.1.2 Estimation of Load Requirements-In estimating the current to be carried by any conductor the following ratings shall be taken, unless the actual values are known or specified for these elements:

<u>Element</u>	<u>Rating in watts</u>
Incandescent lamps	60
Ceiling fans	60
Table fans	60
Ordinary socket outlet points	1000
Fluorescent tubes:	
Length: 600 mm	25
1200 mm	50
1500 mm	90
Power socket-outlet	3000

- 6.1.3 Electrical installation in a new building shall normally begin immediately on the completion of the main structural building work and before finishing work such as plastering has begun except in the case of surface wiring which can be carried out after the plaster work. Usually, no installation work should start until the building is reasonably weatherproof, but where electric wiring is to be concealed within the structures as may be the case with a reinforced concrete building, the necessary conduits and ducts shall be positioned firmly by tying the conduit to the reinforcement before concreting. When shutters are removed after concreting, the conduit ends shall be given suitable anti-corrosive treatment and holes blocked off by putties or caps to protect conduits from getting blocked.
- 6.1.4 Selection of Size of Conductors-The size of conductors of circuits shall be so selected that the drop in voltage from consumer's terminals in a public supply (or from the bus-bars of the main switchboard

controlling the various circuits in a private generation plant) to any point on the installation does not exceed the provision of electricity rule 2050 at the consumer's terminals (or at two bus-bars as these may be) when the conductors are carrying the maximum current under the normal conditions of service.

- 6.1.5 **Layout & Installation Drawing:** The electrical layout should be considered after proper locations of all outlets for lamps, fans, and appliances both fixed and transportable, motors, etc. have been selected and best methods of wiring determined. All runs of wiring and the exact positions of all points of switch-boxes and other outlets shall be first marked on the plans of the building and approved by the engineer-in-charge or the owner before actual commencement of the work. The layout of wiring should be designed keeping in view disposition of the lighting system to meet the illumination levels. "Power" and 'heating' sub-circuits shall be kept separate and distinct from 'lighting' and 'fan' sub-circuits. All wirings shall be done on the distribution system with main and branch distribution boards at convenient physical and electrical load centres. All types of wiring, whether concealed or unconcealed should be as near the ceiling as possible. In all types of wirings due consideration shall be given for neatness and good appearance.
- 6.1.6 **Balancing of circuits in three phase - installation shall be arranged before hand.** Conductors shall be so enclosed in earthed metal or incombustible insulating material that it is not possible to have ready access to them unless the points between which a voltage exceeding 250 volts may be present are 2 m or more apart, in which case means of access shall be marked to indicate the voltage present. Where terminals or other fixed live parts between which a voltage exceeding 250 V exists are housed in separate enclosures or items of apparatus which, although separated are within reach of each other, a notice shall be placed in such a position that anyone gaining access to live parts is warned of the magnitude of the voltage that exists between them.

## 6.2 *Non-Metallic surface & recessed conduit wiring:*

### 6.2.1 *Type and size of conduits-*

All rigid non-metallic conduits used shall conform to accepted standards IS1653-1972 and shall be used with corresponding accessories IS 3419-1977; 9537; 9537 (part 1) 1980. All flexible non-metallic conduits shall conform to accepted standards IS 1653-1972 The conduits shall provide adequate mechanical protection for the enclosed cables. The interior of the conduits shall be free from obstructions. Flexible non-metallic conduits shall be used only at terminations, wherever specified. The conduits shall be circular in cross-section. The conduits shall be designated by their nominal outside diameter. The conduit wiring system shall be complete in all

respect including accessories. No non-metallic conduit less than 20 mm in diameter shall be used.

### 6.2.2 Conduit Accessories

Rigid conduit accessories shall be normally of grip type. Flexible conduit accessories shall be of threaded type.

### 6.2.3 Wiring Capacity

The maximum number of PVC insulated conductor cable of 250 voltage grade that can be drawn in one conduit of various sizes is given in following Table .

Size of Cable		Size of Conduit (mm)					
Nominal Cross-Sectional Area mm <sup>2</sup>	Number & Diameter (in mm) of Wires-	Number of cables Max					
		16	20	25	32	40	50
1.0	1/1.12 *	5	7	13	20	-	-
1.5	1/1.4	4	6	10	14	-	-
2.5	(1/1.8), (3/1.06*)	3	5	10	14	-	-
4	(1/2.24), (7/1.85*)	2	3	6	10	14	-
6	(1/2.8), (7/1.4*)	-	2	5	9	11	-
10	(1/3.55#), (7/1.4*)	-	-	4	7	9	-
16	7/1.7	-	-	2	4	5	12
25	7/2.24	-	-	-	2	2	6
35	7/2.25	-	-	-	-	2	5
50	(7/3#), (19/1.8)	-	-	-	-	(2), (2)	(5), (3)

\* For copper conductors only.

# For aluminum conductors only.

6.2.4 Bunching of Cables: For ease of maintenance, cables carrying direct current or alternating current shall always be bunched so that the outgoing and return cables are drawn into the same conduits.

6.2.5 Conduit Joints: All joints shall be sealed cemented with approved cement. Damaged conduit pipes fittings shall not be used on the work. Cut ends of conduit pipes shall have no sharp edges nor any burrs left to avoid damage to the insulation of conductors while pulling them through such pipes.

6.2.6 Protection against Condensation: The layout of conduit should be such that any condensation or sweating inside the conduit is drained out. Suitable precaution shall also be taken to prevent entry of insects inside the conduit.

6.2.7 Painting: After installation all accessible surfaces of metallic-accessories shall be painted.

6.2.8 Outlets: The switch box shall be made of either rigid PVC moulding or mild steel or cast iron on all sides except at the front. PVC boxes shall conform to accepted standards IS 3419-1976; 9537, 9537(part 1) – 1980 & 5133(part 2) 1969. These boxes shall be free from burrs, fins and internal roughness. The thickness of the walls and base of PVC boxes shall be not less than 2 mm. The clear depth of PVC boxes shall not be less than 50 mm. For METALLIC boxes: The switch or

regulator box shall be made of metal on all sides, except on the front. In the case of cast boxes, wall thickness shall be at least 3 mm and in case of welded mild steel sheet boxes, the wall thickness shall not be less than 1.18 mm for boxes up to a size of 20 cm X 30 cm and above this 1.6 mm MS boxes shall be used. Clear depth of the box shall not be less than 60 mm and this shall be increased suitably to accommodate mounting of fan regulators in flush pattern. All fittings shall be filled in flush pattern.

Non-Metallic Recessed Conduit Wiring System shall have following three requirements also additionally:

- a) Fixing of Conduit In Chase: The conduit pipe shall be fixed by means of staples or by means of non-metallic saddles placed at not more than 80 cm apart or by any other approved means of fixing. Fixing of standard bends or elbows shall be avoided as far as practicable and all curves shall be maintained by sending the conduit pipe itself with a long radius, which will permit easy drawing in of conductors. At either side of bends, saddles/staples shall be fixed at a distance of 15 cm from the centre of bends.
- b) Types of Accessories to be used: All outlets such as switches, wall sockets, etc, may be either flush mounting type or of surface mounting type.
- c) Inspection Boxes-Suitable inspection boxes to the nearest minimum requirements shall be provided to permit periodical inspection and to facilitate replacement of wires, if necessary. The inspection/junction boxes shall be mounted flush with the wall or ceiling concrete. Where necessary deeper boxes of suitable dimensions shall be used. Suitable ventilating holes shall be provided in the inspection box covers, where required.

## 7. Earthing

7.1 General – The object of an earthing system is to provide as nearly as possible a system of conductors at a uniform potential and as nearly zero or absolute earth potential as possible. The purpose of this is to ensure that in general all parts of apparatus other than live parts shall be at earth potential as well as to ensure that persons coming in contact with it shall also be at earth potential at all times.

- 7.2 Earthing associated with current-carrying conductor is normally essential for the security of the system and is generally known as system earthing, while earthing of non-current carrying metal work and conductor is essential for the safety of human life, of animals and of property and it is generally known as equipment earthing.
- 7.3 Earth Electrodes: Earth electrode either in the form of pipe electrode or plate electrode should be provided at all premises for providing an earth system. Details of typical pipe and plate earth electrodes are given in relevant standard figures.
- 7.4 As far as possible, all earth connections shall be visible for inspection and shall be carefully made; if they are poorly made or inadequate for the purpose for which they are intended, loss of life and property or serious personal injury may result.
- 7.5 The earthing of electrical installations for non-industrial buildings shall be done in accordance with good practice IS 3043-1966.

## **8. Inspection and Testing of Installation:**

- 8.1 General: Before the completed installation, or an addition to the existing installation, is put into service, inspection and testing shall be carried out in accordance with the Electricity Rules, 2050. In the event of defects being found, these shall be rectified, as soon as practicable and the installation retested. Periodic inspection and testing shall be carried out in order to maintain the installation in a sound condition after putting into service. Where an addition is to be made to the fixed wiring of an existing installation, the latter shall be examined for compliance with the recommendations of the Code.
- 8.2 Completion Drawings-On completion of the electric work, initial wiring diagram shall be verified at actual basis of works and submitted to the engineer-in-charge or the owner's representative. All wiring diagrams shall indicate clearly, the main switchboard, the runs of various mains and sub mains and the position of all points and their controls. All circuits shall be clearly indicated and numbered in the wiring diagram and all points shall be given the same number as the circuit in which they are electrically connected. Also the location and number of earth points and the run of each load should be clearly shown in the completion drawings.
- 8.3 On completion of wiring a general inspection shall be carried out by competent Electrical Engineer in order to verify that the provisions of this Code and that of Electricity Rules, 2050 have been complied with. This, among other things, shall include checking whether all equipments, fittings, accessories, wire/cables, used in the installation are of adequate rating and quality to meet the requirement of the load. General workmanship of the electrical wiring with regard to the lay out and finish shall be examined for neatness that would facilitate easy identification of circuits of the system, adequacy of clearances, soundness, contact pressure and contact area. A complete check shall also be made of all the protective devices, with respect to their ratings, range of settings and co-ordination between the various protective devices.

- 8.4 Testing of Installation – After inspection, the following tests shall be carried out, before an installation or an addition to the existing installation is put into service. Any testing of the electrical installation in an already existing installation shall commence after obtaining permit to work from the engineer-in-charge and after ensuring the safety provisions.

#### 8.4.1 *Switchboards*

All earth connections shall be checked for continuity. The operation of the breakers, switches and fuses shall be tested from all control stations. Indication signaling lamps shall be checked for proper working. Contact resistance of main and isolator contacts, cable's contact etc. shall be measured. All high and low voltage switchboards shall be tested for dielectric test as per IS 8623 (part 1) 1977.

#### 8.4.2 *Cables*

It shall be ensured that the cables conform to the relevant Standards. Tests shall also be done in accordance with good practice IS 1255-1967. The insulation resistance before and after the tests shall be checked. The insulation resistance between each conductor and against earth shall be measured. The insulation resistance varies with the type of insulation used and with the length of cable.

#### 8.4.3 *Wiring Installation*

- a) The insulation resistance shall be measured by applying between earth and the whole system of conductor or any section thereof with all fuses in place and all switches closed, and except in earthed concentric wiring, all lamps in position or both poles of installation otherwise electrically connected together, a dc voltage of not less than twice the working voltage, provided that it does not exceed 500 volts for medium voltage circuits. Where the supply is derived from three-wire (ac or dc) or a poly-phase system, the neutral pole of which is connected to earth either direct or through added resistance the working voltage shall be deemed to be that which is maintained between the outer or phase conductor and the neutral.
- b) The insulation resistance in megaohms of an installation measured as in (a) shall be not less than 50 divided by the number of points on the circuit, provided that the whole installation need not be required to have an insulation resistance greater than one megaohm.
- c) Control rheostats, heating and power appliances and electric signs, may, if desired, be disconnected from the circuit during the test, but in that event the insulation resistance between the case or framework, and all live parts of each rheostat, appliance and sign shall be not less than that specified in the relevant Standard specification or where there is no such specification, shall be not less than half a megaohm.

- d) The insulation resistance shall also be measured between all conductor connected to one pole or phase conductor of the supply and all the conductors connected to the middle wire or to the neutral or to the other pole of phase conductors of the supply. Such a test shall be made after removing all metallic connections between the two poles of the installation and in these circumstances the insulation resistance between conductors of the installation shall be not less than that specified in (b)

#### 8.4.4 *Efficiency of Earthing:*

The earth resistance of each electrode shall be measured. Earth resistance of earthing grid shall be measured. All electrodes shall be connected to the grid and the earth resistance of the entire earthing system shall be measured. These tests shall preferably be done during the summer months.

- 8.5 Completion Certificate-On completion of an electrical installation (or an extension to an installation) a certificate shall be furnished by the contractor, counter-signed by the certified electrician engineer under whose direct supervision the installation was carried out. This certificate shall be in a prescribed form

## 9. **Lightning Protection of Buildings.**

While every structure, theoretically, has a chance of being struck by lightning, the degree of this chance varies depending on a number of associated factors, such as lightning incidences, surroundings and types of terrain. For a certain group of occupancies, which form a source of danger, such as those housing explosive factories of stores or flammable materials, complete protection against lightning shall be provided. In other cases, it may be necessary to decide whether this protection is called for, under a given set of circumstances. There are a number of factors, affecting the risk of the structure being struck by lightning and consequential effects of a stroke, which are capable of assessment. There would be other factors, which are not capable of such assessment in relative terms. Yet these may over-ride all other considerations; for example, a requirement that there should be no avoidable risk to life, or the overwhelming importance or value of the structure. In such cases lightning protection shall always be provided. In other cases, however, it may be desirable to make a decision on an assessment in terms of the chances of the structure being struck. For this purpose, various factors denoting chances of the structure being struck by lightning and the total effect of these factors shall be assessed.

## 10. **Telecommunication and other services:**

Layout arrangements, EPABX, methods for internal block wiring and other requirements regarding provisions of space, etc, may be decided depending as the number of phone outlets and other details in consultation with Engineer/Architect and user.

### ***References :* National building code of India 1983**

**Electricity Act. 2049**

**Electricity Rule 2050**

**Regulations relating to electrical wiring installations in buildings (CTEVT) 1997.**

**FORM OF COMPLETION CERTIFICATE**  
(CLAUSE 8.5)

I/ We certify that the installation detailed below has been installed by me/us and tested and that to the best of my/our knowledge and belief, it complies with Electricity Rules 2050.

Electrical Installation at .....

Voltage and system of supply .....

Particulars of Works:

a) Internal Electrical Installation.

	No.	Total load	Type or system of wiring
i) Light point.			
ii) Fan point.			
iii) Plug point.			
3-pin 5 A.			
3-pin 15 A.			

b) Others.

Description	hp/kW	Type of starting.
1) Motors:		
i)		
ii)		
iii)		
2) Other plants:		

c) If the work involves installations of over head line and/or underground cable.

- 1)
  - i) Type and description of overheadline.
  - ii) Total length and No. of spans.
  - iii) No. of street lights and its description.

- 2)
  - i) Total length of underground cable and its size.
  - ii) No. of joints:

End joint:

Tee joint:

Straight through joint:

Earthing.

- i) Description of earthing electrode
- ii) No. of earth electrodes
- iii) Size of main earth lead

Test Results:

a) Insulation Resistance

i) Insulation resistance of the whole system of conductors to earth.....Megohms.

ii) Insulation resistance between the phase conductor and neutral.

Between phase R and neutral.....Megohms.

Between phase Y and neutral .....Megohms.

Between phase B and neutral.....Megohms.

iii) Insulation resistance between the phase conductors in case of polyphase supply.

Between phase R and phase Y.....Megohms.

Between phase Y and phase B.....Megohms.

Between phase B and phase R.....Megohms.

b) Polarity test:

Polarity of non-linked single pole branch switches

C) Earth continuity test:

Maximum resistance between any point in the earth continuity conductor including metal conduits and main earthing lead.....Ohms.

d) Earth electrode resistance:

Resistance of each earth electrode.

i).....Ohms.

ii).....Ohms.

iii).....Ohms.

iv).....Ohms.

Signature Of Electrical Engineer

Singature Of Contractor

Name and Address

Name and Address

## **10.3 Annex C: Testing and Commissioning Form**

**Alternative Energy Promotion Center**  
**Solar and Wind Energy Section**  
**Commissioning Test Form for Institutional Solar PV Systems**

**Instructions:**

- i) Please complete this Form at the site obtaining the required information through general observation/ inspection test/measurement and interview/interaction with the end-users, whichever wherever is applicable.
- ii) Please write the appropriate information wherever the space (.....) is given, and tick (√) the appropriate information wherever two or more options are given. For the options 'yes/no' and 'satisfactory/not satisfactory', if the answer is 'no' or 'not satisfactory', please provide additional information explaining the extent of deviation in a separate paper clearly giving cross-references, and attach the paper to this form.
- iii) Enclose photographs of each system installation site clearly showing the installed system including the photos of
  - School Building showing name of school with PV array,
  - battery bank, charge controller, inverter
  - Computers and other appliances

The commissioning test is carried out by:

Name:..... Signature: .....

Name:..... Signature: .....

**1.0 General Information**

- Date of commissioning test: year: ..... month: ..... day: .....
- General weather condition of the day: i) sunny ii) cloudy iii) partly cloudy
- Further information on weather (*information on sunshine for the last 2/3 days*):  
 .....
- Name of end user institution:  
 .....
- Address of the end-user (*address of the premises where the system is installed*):  
 District: ..... Rural Municipality /Municipality.....  
 Ward number: ..... Tole/Settlement: .....  
 Contact phone of end-user institution (if available): .....
- Name of the installation company:  
 .....
- Installation completion date: year: ..... month: ..... day: .....

## 2.0 Information on procurement process:

2.1 Has the institution collected SQ from at least 3 AEPC listed company in format provided by AEPC?

i) yes

ii) no

2.2 Name & Address of companies submitting sealed quotation:

Company 1: .....

Company 2: .....

Company 3: .....

2.3 Are all SQ document properly signed and stamped by institution and company? i) yes ii) no

2.3 Has the institution prepared SQ evaluation report in format provided by AEPC? i) yes ii) no

2.4 Has the institution signed an agreement with responsive lowest bidder in format provided by AEPC?

i) yes

ii) no

*(Note: Please collect copy of all above mentioned documents)*

## 3.0 Site Electrification Status

3.1 Is the ward electrified by any source of electricity? i) yes ii) no

3.2 If yes, source of electrification? i) National Grid ii) Micro Hydro iii) Pico Hydro iv) Others (please specify).....

3.3 If electrified by Micro Hydro or Pico Hydro please specify the size of it.....kW

3.4 If ward is electrified, does institution has connection of electricity supply? i) yes ii) no

3.5 If not connected, distance of nearest connection point from institutions:.....meter/kilometer

3.6 If connected, does the institution receive a reliable and uninterrupted electricity supply? i) yes ii) no

3.7 If no, specify the average duration of electricity outages per day: ..... hours.

## 4.0 Equipment and Installation Work

### 4.1 PV modules/PV array

Manufacturer's name: ..... Model No.: .....

Cell Type: i) Mono crystalline ii) Poly crystalline iii) Thin Film

The serial number of the module is encapsulated inside the PV module i) yes ii) no

Maximum power of each module: ..... Total number of modules: .....

Serial number of each individual module:

Module 1: ..... Module 2: .....; Module 3: .....

Module 4: ..... Module 5: .....; Module 6: .....

Module 7: .....Module 8: .....; Module 9: .....

Module 10: ..... Module 11: .....; Module 12: .....





- Battery bank voltage (all loads off):.....V
- Battery bank voltage (all loads on):.....V

#### 4.4 Charge controller

- Manufacturer's name: ..... Model No.: .....
- Type: i) PWM ii) MPPT
- Maximum input current: ..... Amps
- Maximum load current: .....Amps
- Nominal voltage: ..... V
- Serial number: .....
- The following minimum information is included in the label of the Charge Controller: i) yes, ii) no
  - Manufacturer name:
  - Brand/Model and type
  - Maximum input current in Ampere
  - Maximum load current in Ampere
  - Nominal voltage in volt
  - Serial number
- Charge controller includes LED indications for: solar charging status, battery status and fault.
  - i) yes ii) no
- Charge controller includes LCD display for, PV voltage, charging current, PV power, battery voltage etc.
  - i) yes ii) no

#### *Charge Controller installation and accessories*

- The connections at the PV and battery terminals are done using copper cables shoe.
  - i) yes ii) no
- The cable used from PV array to controller is according to design.
  - i) yes ii) no
- The cable used from battery bank to controller is according to approved design.
  - i) yes ii) no
- The charge controller is accessible for regular cleaning.
  - i) yes ii) no
- The charge controller is installed properly and cable conductors are not open at terminals
  - i) yes ii) no
- The charge controller is functioning properly.

- i) yes                      ii) no

**Measurements:**

- Charge controller input voltage:.....V
- Charge controller input current:.....A
- Charge controller output voltage:.....V
- Charge controller output current:.....A

**4.5 Inverter**

- Manufacturer’s name: .....• Model No.: .....
- Type: .....
- Rate power: ..... VA
- Battery voltage: .....V
- Inverter input voltage: ..... V
- Inverter output voltage: .....V
- Inverter efficiency: .....
- Serial number: .....

***Inverter installation and accessories***

- The inverter is accessible for regular inspection and maintenance.  
i) yes                      ii) no
- The inverter is installed properly (according to manufacturer installation guide).  
i) yes                      ii) no
- The inverter is functioning properly.  
i) yes                      ii) no

**Measurements:**

- *all AC load on*
  - Total AC load: ..... W
  - Input DC current (Ii): ..... A;                      Output DC current (Io): ..... A
  - Input DC voltage (Vi): .....V;                      Output DC voltage (Vo): .....V
  - Inverter input power:.....W;                      Inverter output power: .....W

**4.6 Earthing**



Declaration by End User Representative:

मथि पेश भएको विवरण बमोजिमको सौर्य ऊर्जा प्रणाली यस संस्थामा श्री .....प्रा. लि. बाट जडान भएको कुरा साँचो हो । केन्द्र र यस संस्था सँग भएको सम्झौता बमोजिम सम्पूर्ण खरिद प्रक्रिया अगाडि बढाइएको र सो प्रक्रियामा कुनै गल्ती भएमा हामी पूर्ण जिम्मेवारी लिनेछौं । साथै यो भन्दा अगाडि संस्थागत सौर्य ऊर्जा प्रणाली जडान गर्नका लागि कन्ट्रिवाट अनुदान लिएका छैनौ ।

- Name: .....
- Position/title: .....
- Signature: .....



2. Contractor's representative (if present):

Declaration by Contractor

- Name: .....
- Position/title: .....
- Signature: .....

3. AEPC's representative

- Name.....
- Position/Title :.....
- Signature .....

## **10.4 Annex D: Environmental and Social Management Plan (ESMP)**

## **Annex E: Environmental and Social Management Plan (ESMP)**

The Installation Company shall comply with **applicable** Environmental and Social Management plan proposed below throughout the Installation Company's term and as a part of Installation Company's Scope of Work.

S.N.	Environmental Impacts	Mitigation Measures	Responsible Authority	Extent	Timing of Action
<b>Physical Environment</b>					
<b>1. Construction Phase</b>					
1.1	Change in land use pattern of construction site	Efforts will be made to acquire/use the required land only (limited impact expected due to limited size of PV Array)	Institution/Installation Company	Location of the PV Array (when ground mounted)	Construction Phase
1.2	Noise nuisance to nearby community from construction workforce and machineries	Restriction on the use of heavy machinery, in the night time zone (17 hours to 6 hours of the day) at the project development site	Installation Company	Construction site	Construction Phase
		Regular maintenance of equipment and machineries to minimize the mechanical noise	Installation Company	Construction site	Construction Phase
		Provision of camp for the construction work force	Installation Company	Construction camp	Construction Phase
1.3	Deterioration of ambient air quality by particulates	Regular sprinkling of water in the construction site to minimize the fugitive dusts	Installation Company	Construction site	Construction Phase
		Regular sprinkling of water in earthen road of construction site to minimize the fugitive dusts	Installation Company	Construction Site/Project Access Road	Construction Phase
		All vehicles and machinery used in the project will be in compliance with emission standards set for vehicles and machinery	Installation Company	Construction Site	Construction Phase
		Careful handling during loading and unloading of dusty materials	Installation Company	Construction Site	Construction Phase
		Transportation of Construction materials in covered containers	Installation Company	Construction Site	Construction Phase

S.N.	Environmental Impacts	Mitigation Measures	Responsible Authority	Extent	Timing of Action
		Provision of gas cooking system in construction camp to avoid firewood pollution by firewood	Installation Company	Construction camp	Construction Phase
1.5	Pollution of water bodies	Ensure all the camp wastes and construction wastes are placed in the designated waste collection pits away from the water path	Installation Company	Construction camp/ Construction site	Construction Phase
		Prohibition of disposing the waste directly into the water bodies in the construction site	Installation Company	Construction site/ Project site	Construction Phase
		Construction of Sanitary toilets in the construction camp and near project site for the construction workers	Installation Company	Construction camp	Construction Phase
1.6	Obstruction of natural drainage by construction activities	Disposal of the spoils at the proper site	Installation Company	Spoil Disposal Site	Construction Phase
		Construction of adequate drainage structures	Installation Company	Construction site	Construction Phase
1.7	Land pollution from haphazard disposal of construction wastes, campsite waste and organic waste	The generated solid waste in the construction site will be separated and reused as much as possible	Installation Company	Construction site	Construction Phase
		The left over materials such as like packing materials, left over reinforcement bars will be sold to scrap dealers	Installation Company	Construction site	Construction Phase
		The unused construction solid waste will be collected and disposed at proper safe place	Installation Company	Construction site	Construction Phase
		Open defecation will be strictly prohibited.	Installation Company	Construction camp	Construction Phase
		Construction of Sanitary toilets in the construction camp and near project site for the construction workers	Installation Company	Construction camp	Construction Phase
<b>2. Operational Phase</b>					
2.1	Land and water pollution due to haphazard disposal of used battery	Development of proper battery disposal plan	Institution	Presence of used battery at site	Operation Phase

S.N.	Environmental Impacts	Mitigation Measures	Responsible Authority	Extent	Timing of Action
		Disposal of battery at designated site	Institution	Presence of used battery at site	Operation Phase
<b>Biological Environment</b>					
<b>1. Construction Phase</b>					
1.1	Avian species losing feeding ground	Efforts will be made to acquire the required land only (not so applicable due to limited size of the systems)	Installation Company	Construction site	Construction Phase
1.2	Utilization of forest resources from forest nearby the construction site such as firewood, timber, etc by construction workers for cooking, heating and establishment of temporary huts	Firewood will be strictly prohibited in the construction camps for cooking or any other purpose	Installation Company	Construction camp	Construction Phase
		Alternate source of energy such as kerosene, LPG will be supplied to the construction workforce (if construction camp is established)	Installation Company	Construction camp	Construction Phase
		The construction workers will be prohibited to collect firewood, timber and other forest products from the local forests	Installation Company	Construction camp/Project site	Construction Phase
		The construction workers and project staff will be subjected to awareness programs regarding forest conservation	Installation Company	Construction Camp	Construction Phase
1.3	Disturbance to wildlife habitat by construction activities	Construction works, vehicular movement, light etc will be restricted at night time	Installation Company	Construction site	Construction Phase
		Labors will be instructed for execution of construction related works that secures least disturbance to wildlife	Installation Company	Construction site	Construction Phase
		The construction workers and project staff will be subjected to awareness programs regarding wildlife conservation	Installation Company	Construction site	Construction Phase

S.N.	Environmental Impacts	Mitigation Measures	Responsible Authority	Extent	Timing of Action
1.4	Illegal hunting of wildlife by project workers and outside people	The construction workers and project staff will be prohibited to enter the forest	Installation Company	Construction Camp/project site	Construction Phase
		The meat of wildlife will be prohibited in the construction camps/site	Installation Company	Construction Camp/site	Construction Phase
		Any construction worker or project personnel found involved in hunting of wild animals will be immediately replaced from construction team	Installation Company/ Institution	Construction Camp	Construction Phase
1.5	Increased fishing activities in the streams nearby project site	The construction workers and project personnel will be prohibited for fishing activities	Installation Company/ Institution	Construction Camp/ Project site	Construction Phase
<b>Socio Economic and Cultural Environment</b>					
<b>1.Construction Phase</b>					
1.1	Additional Pressure on health, water supply and sanitation management in the project site	Construction of Sanitary toilets in the construction camp and near project site for the construction workers	Installation Company	Construction camp	Construction Phase
		Provision of the first aid kit with instruction of application in the construction sites and proper management of treatment facilities for sick/injured workers at the hospital nearby project site	Installation Company	Construction camp	Construction Phase
		Local people will be prioritized for employment in project construction works	Installation Company/ Institution	Construction camp / Project site	Construction Phase
1.2	Occurrence and transmission of communicable and STD diseases	Health check-up will be carried out with all the construction workers & project staffs before recruiting in the project and only the healthy workers will be selected	Installation Company	Construction camp/site	Construction Phase
		Regular health check-up of worker and project personnel	Installation Company	Construction camp	Construction Phase
		Launching of community awareness program on communicable disease and	Installation Company	Construction camp / Project site	Construction Phase

S.N.	Environmental Impacts	Mitigation Measures	Responsible Authority	Extent	Timing of Action
		STD and measures to prevent such disease			
1.3	Occurrence of incidents of theft and burglary in project area	Outside workers will be encouraged to stay in construction camp by arranging necessary recreational facilities within the camp (if construction camp is built)	Installation Company	Construction Camp	Construction Phase
		The project will make necessary arrangement to address grievance of local communities related to the project	Institution	Project site	Construction Phase
		Awareness training will be provided to construction workers	Installation Company	Construction camp	Construction Phase
1.4	Occurrence of anti-social activities such as alcohol consumption, gambling, quarrel, etc	The construction workers and project staffs will be prohibited of alcohol consumption outside construction camps	Installation Company	Construction camp/ Project site	Construction Phase
		The project personnel involved in alcohol consumption, gambling, quarrel, etc outside the camp will be penalised as well as replaced from construction team	Installation Company	Construction camp/ Project site	Construction Phase
		Awareness training will be provided to construction workers	Installation Company	Construction camp	Construction Phase
1.5	Conflict between project personnel and local people due to personal ego	The outside construction workers and project staffs will be instructed to respect the local tradition, culture and rituals by conducting awareness program	Installation Company	Construction camp	Construction Phase
1.6	Adverse influence of construction workers in the local culture and traditions	Instruction to the construction workforce to respect local tradition culture	Installation Company	Construction camp	Construction Phase
		Dismissal of the outside workforce from the job that are found in offending local culture and tradition	Installation Company	Construction camp	Construction Phase

S.N.	Environmental Impacts	Mitigation Measures	Responsible Authority	Extent	Timing of Action
		Priority will be given to local employment	Installation Company / Institution	Construction camp/Project site	Construction Phase
1.7	Reduce in aesthetics of project area by stockpiling of construction materials	Proper stockpiling of construction materials in designated site	Installation Company	Construction Site	Construction Phase
1.8	Traffic Congestion in project area	Placing of hoarding boards, and traffic signs in the critical site disturbing traffic	Installation Company	Project access road	Construction Phase
		Limiting speed for project vehicles	Installation Company/Institution	Project access road	Construction Phase
1.9	Injury to construction worker (Impact of Occupational health and Safety hazards) and to people working at the institution (or living around)	Provision of the first aid kit with instruction of application in the construction sites	Installation Company	Construction Site	Construction Phase
		Provision of the personal protective equipment such as helmets, boots, gloves, air mask, etc. as to the requirement to the construction workforce	Installation Company	Construction Site	Construction Phase
		Instruction to the construction workforce regarding occupational and safety hazards	Installation Company	Construction Site	Construction Phase
		Proper management of treatment facilities for sick/injured workers at the health center or hospital nearby project site	Installation Company	Construction Site	Construction Phase
		Insurance provision of construction workers	Installation Company	Construction Site	Construction Phase
		Proper warning signs against electrical and acid hazards (when applicable) and protective barrier/fence around installation area (to avoid entrance of unauthorized people during installation of the system)	Installation Company	Construction Site	Construction Phase

S.N.	Environmental Impacts	Mitigation Measures	Responsible Authority	Extent	Timing of Action
<b>2.Operational Phase</b>					
2.1	Injury to people working at the institution (or living around)	Display Board (or permanent sticker) with Safety Instructions to working personnel at project site to shut down the system	Installation Company (for the installation of the Display Board) AND Institution (for the maintenance the Display Board)	Technical Room	Operation Phase
		Proper management of treatment facilities for injured workers at the health center or hospital nearby project site	Institution	N/A	Operation Phase
		Provision of the first aid kit with instruction of application	Institution		Operation Phase
		Provision of the personal protective equipment (glasses and gloves)	Installation Company	Technical Room	Operation Phase
		Proper training to operational staff on operation and maintenance of system	Installation Company	N/A	Operation Phase
		Proper warning signs against electrical and acid hazards (when applicable)	Installation Company (for the installation) AND Institution for the maintenance of such warning signs	Technical Room and PV array	Operation Phase
		All system components shall be accessible by authorized personal only (fence around PV array, access to technical room, etc.)	Institution	Technical Room and PV array	Operation Phase

# Section-V: Sample Forms

## Price Quotation and Price Schedules

Date:

To:

.....Name of Employer  
.....Address of Employer

Having examined the Direct Purchase (DP) documents, we the undersigned, offer to .....(Title of the Task) in conformity with the said DP documents for the sum of NRs. **In Figure:** .....(In Words: .....) **including of all taxes and VAT** or such other sums as may be ascertained in accordance with the Schedule of Prices attached herewith and made part of this Price Quotation.

We undertake, if our Price Quotation is accepted, to deliver the goods in accordance with the delivery schedule specified in the Schedule of Requirements.

We agree to abide by this price Quotation for a Period of **30** days from the last date fixed for submission of the Price Quotation.

Until a formal Contract is prepared and executed, this Price Quotation, together with your written acceptance thereof and your notification of award, shall constitute a binding Contract between us.

**We declare that, we have not been blacklisted and there is no conflict of interest in the proposed procurement proceedings and we have not been punished for an offence relating to the concerned profession or business.**

We understand that you are not bound to accept the lowest or any Price Quotation you may receive.

Dated this \_\_\_\_\_ day of \_\_\_\_\_ 20\_\_\_\_\_.

\_\_\_\_\_

[signature]

[in the capacity of]

Duly authorized to sign Price Quotation for and on behalf of \_\_\_\_\_

## Price Schedule (BoQ)

Name of Supplier/Bidder \_\_\_\_\_

A	B	C	D	E	F	G=DxF
Item	Description	Unit	Quantity	Unit price In Figure (NRs.)	Unit price In Words (NRs.)	Total Amount (NRs.)
1	Solar PV Modules (≥1,000 Wp)	Pc				
2	Solar Charge Controller (≥1,400 Wp DC input)	Pc	1			
3	Battery Bank (≥7,200 Whr – C10)	Pc				
4	Inverter (≥2,000 VA)	Pc	1			
5	Mounting Structure	Set	1			
6	Earthing and Lightning Protection System	Set	1			
7	Cable and Conduits	Set	1			
8	Spare Parts and Tools	Set	1			
9	Installation Materials	LS	1			
10	Transportation	LS	1			
11	Installation Charge	LS	1			
<b>A</b>	<b>Total Amount (NRs.)</b>					
<b>A1</b>	<b>Total duties, taxes, import duties and other levies for the contract included in total Amount (A) in NRs.</b>					
<b>B</b>	<b>Less: Discount .....% of Total Amount</b>					
<b>C</b>	<b>Net Amount (A-B)</b>					
<b>D</b>	<b>Total of VAT Free Items</b>					
<b>E</b>	<b>Total of Taxable Items (C-D)</b>					
<b>F</b>	<b>Add: Value Added Tax (13% of Taxable Items “E”)</b>					
<b>G</b>	<b>Total Amount Including all applicable taxes and VAT in Figure (C+F)</b>					
<b>Total Amount Including all applicable taxes and VAT in Words:</b>						

**Note:**

- In case of discrepancy between unit price and total, the unit price shall prevail.
- In case of discrepancy between amount (Unit Rate) in figure and words, the amount in words shall prevail.
- Unit price shall include all expenses including custom duties and taxes (Excluding VAT), transportation, insurance cost etc. to the final destination as specified in Schedule of requirement.

## **Declaration of Undertaking**

Reference name of the Application/Offer/Contract: **Supply, Delivery and Installation of 1 kWp Institutional Solar PV System ("Contract")**<sup>1</sup> for .....[name of institution]

To: (**"Project Executing Agency"**)

1. We recognise and accept that KfW only finances projects of the Project Executing Agency ("PEA")<sup>2</sup> subject to its own conditions which are set out in the Funding Agreement it has entered into with the PEA. As a matter of consequence, no legal relationship exists between KfW and our company, our Joint Venture or our Subcontractors under the Contract. The PEA retains exclusive responsibility for the preparation and implementation of the Tender Process and the performance of the Contract.
2. We hereby certify that neither we nor any of our board members or legal representatives nor any other member of our Joint Venture including Subcontractors under the Contract are in any of the following situations:
  - 2.1) being bankrupt, wound up or ceasing our activities, having our activities administered by courts, having entered into receivership, reorganisation or being in any analogous situation;
  - 2.2) convicted by a final judgement or a final administrative decision or subject to financial sanctions by the United Nations, the European Union or Germany for involvement in a criminal organisation, money laundering, terrorist-related offences, child labour or trafficking in human beings; this criterion of exclusion is also applicable to legal Persons, whose majority of shares are held or factually controlled by natural or legal Persons which themselves are subject to such convictions or sanctions;
  - 2.3) having been convicted by a final court decision or a final administrative decision by a court, the European Union, national authorities in the Partner Country or in Germany for Sanctionable Practice in connection with a Tender Process or the performance of a Contract or for an irregularity affecting the EU's financial interests (*in the event of such a conviction, the Applicant or Bidder shall attach to this Declaration of Undertaking supporting information showing that this conviction is not relevant in the context of this Contract and that adequate compliance measures have been taken in reaction*);
  - 2.4) having been subject, within the past five years to a contract termination fully settled against us for significant or persistent failure to comply with our contractual obligations during such Contract performance, unless this termination was challenged and dispute resolution is still pending or has not confirmed a full settlement against us;
  - 2.5) not having fulfilled applicable fiscal obligations regarding payments of taxes either in the country where we are constituted or the PEA's country;
  - 2.6) being subject to an exclusion decision of the World Bank or any other multilateral development bank and being listed on the website <http://www.worldbank.org/debarr> or respectively on the relevant list of any other multilateral development bank (*in the event of such exclusion, the Applicant or Bidder shall attach to this Declaration of Undertaking supporting information showing that this exclusion is not relevant in the context of this Contract and that adequate compliance measures have been taken in reaction*); or
  - 2.7) being guilty of misrepresentation in supplying the information required as condition to participation in this Tender Procedure.

---

<sup>1</sup> Capitalised terms used, but not otherwise defined in this Declaration of Undertaking have the meaning given to such term in KfW's "Guidelines for the Procurement of Consulting Services, Works, Goods, Plant and Non-Consulting Services in Financial Cooperation with Partner Countries".

<sup>2</sup> The PEA means the purchaser, the employer, the client, as the case may be, for the procurement of Consulting Services, Works, Plant, Goods or Non-Consulting Services.

3. We hereby certify that neither we, nor any of the members of our Joint Venture or any of our Subcontractors under the Contract are in any of the following situations of conflict of interest:
  - 3.1) being an affiliate controlled by the PEA or a shareholder controlling the PEA, unless the stemming conflict of interest has been brought to the attention of KfW and resolved to its satisfaction;
  - 3.2) having a business or family relationship with a PEA's staff involved in the Tender Process or the supervision of the resulting Contract, unless the stemming conflict of interest has been brought to the attention of KfW and resolved to its satisfaction;
  - 3.3) being controlled by or controlling another Applicant or Bidder, or being under common control with another Applicant or Bidder, or receiving from or granting subsidies directly or indirectly to another Applicant or Bidder, having the same legal representative as another Applicant or Bidder, maintaining direct or indirect contacts with another Applicant or Bidder which allows us to have or give access to information contained in the respective Applications or Offers, influencing them or influencing decisions of the PEA;
  - 3.4) being engaged in a Consulting Services activity, which, by its nature, may be in conflict with the assignments that we would carry out for the PEA;
  - 3.5) in the case of procurement of Works, Plant or Goods:
    - i. having prepared or having been associated with a Person who prepared specifications, drawings, calculations and other documentation to be used in the Tender Process of this Contract;
    - ii. having been recruited (or being proposed to be recruited) ourselves or any of our affiliates, to carry out works supervision or inspection for this Contract;
4. If we are a state-owned entity, and compete in a Tender Process, we certify that we have legal and financial autonomy and that we operate under commercial laws and regulations.
5. We undertake to bring to the attention of the PEA, which will inform KfW, any change in situation with regard to points 2 to 4 here above.
6. In the context of the Tender Process and performance of the corresponding Contract:
  - 6.1) neither we nor any of the members of our Joint Venture nor any of our Subcontractors under the Contract have engaged or will engage in any Sanctionable Practice during the Tender Process and in the case of being awarded a Contract will engage in any Sanctionable Practice during the performance of the Contract;
  - 6.2) neither we nor any of the members of our Joint Venture or any of our Subcontractors under the Contract shall acquire or supply any equipment nor operate in any sectors under an embargo of the United Nations, the European Union or Germany; and
  - 6.3) we commit ourselves to complying with and ensuring that our Subcontractors and major suppliers under the Contract comply with international environmental and labour standards, consistent with laws and regulations applicable in the country of implementation of the Contract and the fundamental conventions of the International Labour Organisation<sup>3</sup> (ILO) and international environmental treaties. Moreover, we shall implement environmental and social risks mitigation measures when specified in the relevant environmental and social management plans or other similar documents provided by the PEA and, in any case, implement measures to prevent sexual exploitation and abuse and gender based violence.
7. In the case of being awarded a Contract, we, as well as all members of our Joint Venture partners and Subcontractors under the Contract will, (i) upon request, provide information relating to the Tender Process and the performance of the Contract and (ii) permit the PEA and KfW or an auditor appointed by either of them, and in the case of financing by the European Union also to European institutions having competence under European Union law, to inspect the respective accounts, records and documents, to permit on the spot checks and to ensure access to sites

---

<sup>3</sup> In case ILO conventions have not been fully ratified or implemented in the Employer's country the Applicant/Bidder/Contractor shall, to the satisfaction of the Employer and KfW, propose and implement appropriate measures in the spirit of the said ILO conventions with respect to a) workers grievances on working conditions and terms of employment, b) child labour, c) forced labour, d) worker's organisations and e) non-discrimination.

and the respective project.

8. In the case of being awarded a Contract, we, as well as all our Joint Venture partners and Subcontractors under the Contract undertake to preserve above mentioned records and documents in accordance with applicable law, but in any case for at least six years from the date of fulfillment or termination of the Contract. Our financial transactions and financial statements shall be subject to auditing procedures in accordance with applicable law. Furthermore, we accept that our data (including personal data) generated in connection with the preparation and implementation of the Tender Process and the performance of the Contract are stored and processed according to the applicable law by the PEA and KfW.

Name: \_\_\_\_\_ In the capacity of: \_\_\_\_\_

Duly empowered to sign in the name and on behalf of<sup>4</sup>: \_\_\_\_\_

Signature:

Dated:

---

<sup>4</sup> In the case of a JV, insert the name of the JV. The person who will sign the application, bid or proposal on behalf of the Applicant/Bidder shall attach a power of attorney from the Applicant/Bidder.

## Form of Agreement

THIS AGREEMENT made on the .....day of .....[Month Year] between [Name of Institution and address] .....(hereinafter called “the Purchaser”) of the one part and [Name of the Company and address]..... (hereinafter called “the Supplier”) of the other part.

WHEREAS the Purchaser invited Priced Quotation for certain goods and ancillary services, viz., **Supply, Delivery and Installation of 1 kWp Institutional Solar PV System** and has accepted a Price Quotation by the Supplier for the supply of those goods and services in the sum of **Nepalese Rupees.....(Amount in Words: .....)** hereinafter called “the Contract Price”).

NOW THIS AGREEMENT WITNESSES AS FOLLOWS:

1. In this Agreement words and expressions shall have the same meanings as are respectively assigned to them in the Conditions of Contract referred to.
2. The following documents shall be deemed to form and be read and construed as part of this Agreement, viz.:
  - a. The Purchaser’s Notification of Award (*Letter of Acceptance issued by the Purchaser*)
  - b. The Price Quotation Form and the Price Schedule (*As submitted by the Supplier in Section V of the Bidding Document and approved by the Purchaser*)
  - c. The Schedule of Requirements (*As agreed by the Supplier in Section III of the Bidding Document*)
  - d. The Technical Specifications (*As agreed by the Supplier in Section IV of the Bidding Document*)
  - e. The Conditions of Contract (*As agreed by the Supplier in Section II of the Bidding Document*) and
  - f. The Declaration of Undertaking (*As agreed by the Supplier in Section V of the Bidding Document*)
3. In consideration of the payments to be made by the Purchaser to the Supplier as hereinafter mentioned, the Supplier hereby covenants with the Purchaser to provide the goods and services and to remedy defects therein in conformity in all respects with the provisions of the Contract.
4. The Purchaser hereby covenants to pay the Supplier in consideration of the provision of the goods and services and the remedying of defects therein, the Contract Price or such other sum as may become payable under the provisions of the contract at the times and in the manner prescribed by the Contract.

IN WITNESS whereof the parties hereto have caused this Agreement to be executed in accordance with their respective laws the day and year first above written.

On behalf of the Purchaser	On behalf of the Supplier
Name: .....	Name: .....
Designation:	Designation:
Stamp:	Stamp: